

**Specifications, Standards and  
Testing Methods for  
Foodstuffs, Implements,  
Containers and Packaging,  
Toys, Detergents 2008**

**January 2009**

**JETRO** Japan External Trade  
Organization

# Preface

This document is an unofficial English translation of -Specifications and Standards for Food, Additives, etc.|| (Ministry of Health and Welfare Notice No. 370, December 28 1959; last amendment: Ministry of Health, Labour and Welfare Notice No. 529, November 27, 2008), which complies with the provisions of Article 7 paragraph 1 and Article 10 paragraph 1 of the Food Sanitation Act (Act No. 233, 1947, last amendment: Act No. 53 June 7, 2006)\*.

The document contains the standards and testing methods specified in sections I, III, IV, and V—I -Food,|| III -Implements, Containers, and Packaging,|| IV -Toys,|| and V -Detergents||—of the -Specifications and Standards for Food, Additives, etc.|| As for section II -Additives,|| which is not covered in the document, please refer to *-Japan's Specifications and Standards for Food Additives* (the 8th edition)||, published by the Ministry of Health, Labour and Welfare. For an outline of the regulations of food additives, please refer to the publication, *-Specifications and Standards for Foods, Food Additives, etc. under the Food Sanitation Act (Abstract) 2008* ||.

<http://www.jetro.go.jp/en/reports/regulations/pdf/foodadd2009-e.pdf>

\*Note: In the amended act, Article 7 paragraph 1 and Article 10 paragraph 1 correspond to Article 11 paragraph 1 and Article 18 paragraph 1, respectively.

# Content

Preface.....	1
Content.....	2
I. Standards and Testing Methods for Foodstuffs.....	3
A. General Compositional Standards for Food.....	3
B. General Food Production, Processing and Preparation Standards .....	9
C. General Food Storage Standards .....	11
D. Specific Food Items.....	14
II. Standards and Testing Methods for Implements, Containers and Packaging.....	85
A. Standards for General Implements, Containers, Packaging, and Component Materials .....	85
B. Testing Methods for General Implements, Containers, and Packaging .....	86
C Reagents and Solutions .....	105
D. Material-specific Specifications for Implements, Containers, and Packaging, and Raw Materials.....	113
E. Application-specific Specifications for Implements, Containers, and Packaging.....	129
F. Implements, Containers, and Packaging Production Standards.....	136
III. Standards and Testing Methods for Toys .....	138
A. Standards for Toys and Component Materials .....	138
B. Toys Production Standards.....	144
IV. Standards and Testing Methods for Detergents .....	145
B. Standards for Using Detergents .....	148

# I. Standards and Testing Methods for Foodstuffs

## A. General Compositional Standards for Food

Ministry of Health, Labour and Welfare (in English)

<http://www.mhlw.go.jp/english/topics/foodsafety/index.html>

### 1

Foods shall not contain any antibiotics or chemically synthesized antibacterial substances (substances obtained by instigating chemical reactions to elements and/or compounds through chemical methods, except for decomposition; this applies hereinafter in this paragraph), except for the following cases:

- (1) When the substance concerned is identical to the food additive determined by the Minister of Health, Labour and Welfare as having no potential to cause damage to human health under Article 10 of the Food Sanitation Act (Act No. 233, 1947, hereinafter —the Act.))
- (2) When compositional standards are set forth in 5, 6, 7, 8 or 9 below for the substance concerned.
- (3) When the food product concerned has been manufactured or processed using a food ingredient that meets the compositional standards given in 5, 6, 7, 8 or 9 below (except for foods containing antibiotics or chemically synthesized antibacterial substances for which compositional standards are not set forth in 5, 6, 7, 8 or 9 below.)

### 2

Foodstuffs that are all or part of an organism derived by DNA recombination (i.e. a technology that uses enzymes, etc. to cut and reunite DNA, thus creating recombinant DNA molecules in which different DNA is joined together, and then transferring this into living cells and propagating them; the same applies below) or that contain all or part of such an organism must be marked to show that the organism has undergone the safety inspection procedures prescribed by the Minister of Health, Labour and Welfare.

### 3

Foodstuffs manufactured using microorganisms derived by DNA recombination or containing such substances must be marked to show that the substances have undergone the safety inspection procedures prescribed by the Minister of Health, Labour and Welfare.

## 4

Foods for specified health use as prescribed in the Food Sanitation Act enforcement regulations (Ministry of Health, Labour and Welfare Ordinance No. 23 of 1948) Article 21, Paragraph 1-1-xli must undergo the safety and effectiveness inspection procedures prescribed by the Minister of Health, Labour and Welfare.

## 5

Foods shall not contain substances (including substances produced by chemical transformation: this applies hereinafter in this paragraph) used as ingredients of agricultural chemicals and other chemical substances listed in the table in (1) below. The agricultural chemicals and other Provisional Translation from Japanese Original 2/103 hemical substances stated above, here and also later in this paragraph, refer to substances used for purposes designated by the Agriculture, Forestry and Fisheries Ministerial Ordinance according to the provision of Paragraph 3 of Article 2 of the Law Concerning Safety Assurance and Quality Improvement of Agricultural Chemicals and Feeds (Law No. 35, 1953), which is stipulated under Paragraph 1 of Article 1-2 of the Agricultural Chemicals Regulation Law (Law No. 82, 1948), with such aims as adding to, mixing with, or infiltrating into feeds (the feeds stipulated under Paragraph 2 of Article 2 of Law No. 35), or medical products to be used for animals, which are stipulated in Paragraph 1 of Article 2 of the Pharmaceutical Affairs Law (Law No. 145, 1960). In association with this regulation, a sample of the foods listed in the –foods|| column in the table in (2) below shall be tested using the part listed in the –samples|| column in the table by the testing methods described in (3) to (17)\*. No ingredients of agricultural chemicals or other chemical substances shall be detected in these tests.

\*Explanation of (3) to (17) testing methods are abbreviated. For details, refer to the website of the Ministry of Health, Labour and Welfare (in Japanese only):

<http://www.mhlw.go.jp/topics/bukyoku/iyaku/syoku-anzen/zanryu2/591228-1.html>

### (1) Substances used as ingredients of agricultural chemicals and other chemical substances that are stipulated to be “Not detected” in foods

2, 4, 5-T
Azocyclotin and cyhexatin
Amitrol
Captafol
Carbadox
Coumaphos
Chloramphenicol
Chlorpromazine
Diethylstilbestrol
Dimetridazole
Daminozide
Nitrofurans

Nitrofurantoin
Furazolidone
Furaltadone
Propham
Malachite green
Metronidazole
Ronidazole

## (2) Samples

Food	Sample material
Barley and buckwheat	Threshed seeds
Wheat and rye	Husked seeds
Rice (brown rice)	Husked seeds
Corn (maize)	Seeds with the husks, the silk and the cores removed
Other cereal grains	Threshed seeds
Peas, red beans, broad beans and soybeans	Seeds without the pods
Peanuts	With the shells removed
Other legumes/pulses	Seeds without the pods
Apricot, ume plum, cherry, Japanese plum (including prune) and nectarine	With the peduncle and the seeds removed
Peach	With the skins and the seeds removed
Orange (including navel orange), grapefruit, citrus natsudaidai (whole), lime and lemon	Whole fruit
Citrus natsudaidai (pulp) and unshu orange (pulp)	With the peels removed
Citrus natsudaidai, peels	With the calyxes removed
Other citrus fruits	Whole fruit
Pear, Japanese pear, quince and apple	With the blossom scars, the cores and the peduncles removed
Loquat	With the peduncles, the skins and the seeds removed
Avocado and mango	With the seeds removed
Kiwifruit	With the skins removed
Guava	With the calyxes removed
Date	With the calyxes and the seeds removed
Pineapple	With the tops removed
Passion fruit and papaya	Whole fruit
Banana	With the pedicels removed
Strawberry, cranberry, huckleberry,	With the calyxes removed

blackberry and blueberry	
Raspberry	Whole fruit
Other berries	With the calyxes removed
Japanese persimmon	With the calyxes and the seeds removed
Watermelon, Oriental melon and melons	With the rinds removed
Grape	With the peduncles removed
Other fruits	Edible portions
Turnip (roots), Japanese radish (roots) and radish (roots)	With the dirt lightly rinsed off with water
Turnip (leaves), watercress, kale, Japanese radish (leaves), radish (leaves) and brussels sprouts	With the decayed leaves removed
Cauliflower and broccoli	With the leaves removed
Cabbage and Chinese cabbage	A sample consisting of one portion from each of four heads, with each head equally cut into four portions, without the decayed outer leaves and the cores
Kyona and komatsuna (Japanese mustard spinach)	With the roots and the decayed leaves removed
Horseradish	Roots with the dirt lightly rinsed off with water
Qing-geng-cai and other cruciferous vegetables	Edible portions
Sweet potato, konjak, taro, white potato, yam and other potatoes	With the dirt lightly rinsed off with water
Pumpkin (including squash), cucumber (including gherkin) and Oriental pickling melon (vegetable)	With the vines removed
Other cucurbitaceous vegetables	Edible portions
Artichoke, endive and chicory	With the decayed leaves removed
Burdock and salsify	A sample thinly sliced then ground with a meat grinder, the leaves having been removed and the dirt having been lightly rinsed off with water
Shungiku	With the roots and the decayed leaves removed
Lettuce (including cos lettuce and leaf lettuce)	With the decayed outer leaves and the cores removed
Other composite vegetables	Edible portions
Shiitake mushroom, button mushroom and other mushrooms	Edible portions
Celery, parsley and mitsuba	With the roots and the decayed leaves removed
Carrot and parsnip	With the dirt lightly rinsed off with water

Other umbelliferous vegetables	Edible portions
Tomato, egg plant and pimiento (sweet pepper)	With the calyxes removed
Other solanaceous vegetables	Edible portions
Asparagus	Stems
Onion, garlic, Welsh onion, leek) and wakegi	With the outer skins and the root hair removed
Nira and other liliaceous vegetables	Edible portions
Green soybeans, kidney beans (immature, with pods) and peas (immature, with pods)	With the pedicels removed
Okra	With the calyxes removed
Sugarcane	With the husks removed
Ginger	With the leaves removed, and with the dirt lightly rinsed off with water
Sugar beet	With the dirt lightly rinsed off with water
Spinach	With red roots left on, and with the root hair and the decayed leaves removed
Bamboo shoots and other vegetables	Edible portions
Sesame seeds, rapeseeds, sunflower seeds, safflower seeds, cotton seeds and other oil seeds	Seeds only
Almond, ginkgo nut, chestnut, walnut, pecan and other nuts	With the husks removed
Cacao beans and coffee beans	Beans without the pods
Tea	Tea leaves
Hop	Dried flowers
Other spices and other herbs	Edible portions

## 6

Regardless of the provisions in 5, ingredients of agricultural chemicals and other chemical substances listed in the first column of the table in (1) must not be contained in foods at levels exceeding the limits stipulated in the third column of the same table according to the food categories shown in the second column of the same table. In association with this regulation, foods listed in the -foods|| column in the table in (2) shall be tested using the part listed in the –samples|| column in the table as a sample. In addition, in the substances used as ingredients of agricultural chemicals and other chemical substances listed in the first column of the table in (1), which are stipulated to be –Not detected|| in the third column of the same table in the foods listed in the second column of the same table, no ingredient of agricultural chemicals or other chemical substances shall be detected when these foods are tested using the test methods stipulated in (3) to (10).

\*The tables and the explanation of these testing methods are abbreviated. For details, refer to the website of the Ministry of Health, Labour and Welfare (in Japanese only):

<http://www.mhlw.go.jp/topics/bukyoku/iyaku/syoku-anzen/zanryu2/591228-1.html>

The residual tolerance for each agricultural chemical can be examined on the [website of the Japan Food Chemical Research Foundation](#) (in English):

## **7**

In addition to the substances stipulated under 6, ingredients of agricultural chemicals and other chemical substances listed in the first column of the table in (1) must not be contained in foods at levels exceeding the limits stipulated in the third column of the same table according to the food categories shown in the second column of the same table. Concerning this, foods listed in the –foods|| column in the table in (2) shall be tested using the part listed in the –samples|| column in the table as a sample. In addition, in the substances used as ingredients of agricultural chemicals and other chemical substances listed in the first column of the table in (1), which are stipulated to be –Not detected|| in the third column of the same table in the foods listed in the second column of the same table, no ingredient of agricultural chemicals or other chemical substances shall be detected when these foods are tested using the test methods stipulated in (3) to (8).

\*The tables and the explanation of these testing methods are abbreviated. For details, refer to the website of the Ministry of Health, Labour and Welfare (in Japanese only):

<http://www.mhlw.go.jp/topics/bukyoku/iyaku/syoku-anzen/zanryu2/591228-1.html>

## **8**

In cases where a substance used as an ingredient of an agricultural chemical (excluding substances determined by the Minister of Health, Labour and Welfare as having no potential to cause damage to human health under Paragraph 3 of Article 11 of the Act), for which no compositional standards are stipulated in 5 to 7, is the same as the substance naturally contained in the food, the amount of the substance contained in the food shall not exceed the amount normally contained in the food. This, however, does not apply to foods containing substances that may cause damage to human health at the amount normally contained.

## **9**

In cases where substances used as ingredients of agricultural chemicals and other chemical substances that are listed in the first column of the following table\* are contained in a food, the amount of the substances shall not exceed the amount stipulated in the third column of the same table according to the food categories shown in the second column of the same table.

\*The table is abbreviated. For details, refer to the website of the Ministry of Health, Labour and Welfare (in Japanese only):

## **10**

In addition to the provisions of 6 or 9, when food products are manufactured or processed using foods for which compositional standards are specified in 6 through 9, the foods used must comply with the standards given in 6 through 9.

## **11**

In addition to the provisions of 6 or 9, food products that are manufactured or processed using foods for which compositional standards are not specified in 5 through 9 shall not contain substances used as agricultural chemicals nor other chemical substances in excess of the amount determined by the Minister of Health, Labour and Welfare as having no potential to cause damage to human health under Paragraph 3 of Article 11 of the Act (excluding substances determined by the Minister of Health, Labour and Welfare as having no potential to cause damage to human health under Paragraph 3 of Article 11 of the Act).

## **B. General Food Production, Processing and Preparation Standards**

### **B-1**

When food is to be produced or processed, it must not be exposed to radiation (as stipulated in Article 3, No. 5 of the Atomic Energy Basic Law (No.186, 1955); hereafter the same in Part I: Foodstuffs). However, this does not apply if food is exposed to radiation during any processes in the production or processing of food in order to control those processes, if the dosage to which the food is exposed is no more than 0.10 Gy, or if there are special provisions in the items under Section D: Specific Food Items.

### **B-2**

When food is to be produced using fresh cow's milk or fresh goat's milk, during the production of that food the fresh cow's milk or fresh goat's milk must either be pasteurized for 30 minutes at 63°C by means of a holding system or pasteurized using a method that achieves an equivalent or better pasteurization effect.

The milk added to food or used in preparing food must be cow's milk, special cow's milk, pasteurized goat's milk, homogenized cow's milk, low-fat cow's milk, non-fat cow's milk or processed milk.

### **B-3**

When food is to be produced, processed, or prepared using blood, blood corpuscles, or blood plasma (limited to livestock; hereafter the same), during the production, processing, or preparation of that food, the blood, blood corpuscles, or blood plasma must be sterilized for 30 minutes at 63°C or heated and sterilized using a method that achieves an equivalent or better

sterilization effect.

#### **B-4**

Chicken eggs in their shells used for the production, processing, or preparation of food may not be eggs unfit for eating (defined as rotten eggs in their shells, moldy eggs in their shells, eggs in their shells containing foreign matter, eggs in their shells containing blood, eggs in their shells from which fluids are leaking, or eggs in their shells with broken yolks (with the exception of eggs when their yolks are broken due to physical causes), as well as eggs in their shells that have been heated to initiate hatching when the heating was discontinued at an interim stage; hereafter the same).

When producing, processing, or preparing food using chicken eggs, during the production, processing, or preparation of that food the chicken eggs must be sterilized for at least 1 minute at 70°C or they must be heated and sterilized using a method that achieves an equivalent or better sterilization effect. However, this does not apply when food is to be prepared promptly after breaking normal eggs whose best-before date has not passed, and which are fresh enough to be eaten raw (defined as eggs in their shells other than eggs unfit to be eaten, dirty eggs (in turn defined as eggs in shells contaminated by fecal matter, blood, egg contents, feathers or other matter; hereafter the same), soft eggs (defined as eggs in their shells whose eggshell membrane is sound but whose eggshells are damaged or thin; hereafter the same), or broken eggs (defined as eggs in their shells that appear to be cracked; hereafter the same)); when that food is to be ingested promptly after preparation, and when liquid chicken eggs that have been sterilized (defined as chicken eggs in their shells whose shells have been removed; hereafter the same) are to be used.

#### **B-5**

When seafood is to be prepared to be eaten raw, it must be washed thoroughly in potable water (defined under Part I: Foodstuffs, Section D : Specific Food Items, Sub-section D1: Soft Drink Beverages, Paragraph 2: Production Standards for Soft Drink Beverages, Sub-paragraph b., and all matter that might contaminate the products must be removed.

#### **B-6**

When food is to be produced using microorganisms obtained using recombinant DNA technology, it must be produced using a method recognized as complying with the standards set forth by the Ministry of Health, Labor and Welfare.

\*For details, refer to the website of the Ministry of Health, Labour and Welfare (in English)  
Food safety: <http://www.mhlw.go.jp/english/topics/foodsafety/dna/index.html>

#### **B-7**

When food is to be produced or processed, additives must not be used if they do not comply with the stipulations in Part II: Additives, Section D: Component Standards and Storage

Standards, or if they are additives manufactured by any method that does not comply with Part II: Additives, Section E: Production Standards.

\*For details, refer to the website of the Ministry of Health, Labour and Welfare (in English)  
Food additives: <http://www.mhlw.go.jp/english/topics/foodsafety/foodadditives/index.html>

## **B-8**

When the meat of cattle bred in a country or area where bovine spongiform encephalopathy has occurred (BSE as specified in Article 2 of the Special Measures Law on Bovine Spongiform Encephalopathy (No.70, 2002; such cattle defined as "specific cattle") is to be sold directly to consumers, the vertebral columns of the cattle (with the exception of the transverse processes of thoracic vertebrae, transverse processes of lumbar vertebrae, ala sacralis and caudal vertebrae; hereafter the same) must be removed. The removal of the vertebral columns as specified above must be undertaken using a method capable of preventing contamination, by the dorsal root ganglia, of the meat of the cattle and their internal organs, as well as meat situated in the vicinity of the removal and that is to be supplied for food.

When food is to be produced, processed or prepared, the vertebral columns of specific cattle must not be used as the ingredients of that food. However, this does not apply when the fats and oils from the vertebral columns of the specific cattle are to be used as ingredients after they have undergone hydrolysis, saponification or interesterification under high-temperature and high-pressure conditions.

\*For details, refer to the website of the Ministry of Health, Labour and Welfare (in English)  
BSE:<http://www.mhlw.go.jp/english/topics/foodsafety/bse/index.html>

## **C. General Food Storage Standards**

### **C-1**

When food is to be stored in direct contact with crushed ice other than crushed ice for eating and drinking, crushed ice that tests negative for coliform bacilli (defined as all aerobic or facultative Gram-negative nonspore-forming bacilli that break down lactose and generate acids and gases; hereafter the same) must be used. The following test method is used to detect the coliform bacilli.

### **1. Collecting Test Specimens and Preparing Test Samples**

Wash the test specimen thoroughly in sterile distilled water, place it in a sterilized container, and shake in warm water at room temperature (less than 40°C) until totally dissolved. Immediately prepare a sample solution as well as sample solutions diluted 10x, 100x and 1,000x.

## 2. Coliform Bacilli Test Method

### a. Presumptive test:

In separate fermentation tubes, place 10 ml and 1 ml of the sample solution, as well as 1 ml each of the 10x, 100x and 1,000x diluted solutions. Use Durham or Smith tubes and add a BTB lactose broth in an amount at least double that of the sample solution.

If generation of gases is not discernible after the fermentation tubes have been cultivated for 24 hours (a 2-hour margin either way is acceptable) at 35°C (a 1.0°C margin either way is acceptable), continue the cultivation and observe for up to 48 hours (a 3-hour margin either way is acceptable).

If generation of gases is not discernible after this, the samples are considered negative for the presumptive test. Samples in which the generation of gases is discernible (coliform bacilli tentatively positive) are considered positive.

### b. Confirmation test:

The following steps are to be taken for samples that were positive in the presumptive test. Use an Endo or EMB culture medium, or a BGLB fermentation tube.

Use a platinum loop to streak the sample solution from the tube in which gases were generated during the preliminary test (if gases were generated in several tubes, use the most dilute solution) on an Endo or EMB culture medium, and observe whether an independent colony grows. Alternately, transfer some of the solution to a fermentation tube containing BGLB and cultivate. If after 24 hours a typical colony grows on the Endo or EMB culture medium, the test is considered positive for coliform bacilli. If an atypical colony grows, a conclusive test is required.

If gases are generated in the BGLB fermentation tube within 48 hours, the test is considered positive for coliform bacilli. However, if the culture medium turns brown, a conclusive test should be performed.

### c. Conclusive test:

If a BGLB fermentation tube was used for the confirmation test, first transfer the sample in the tube to an Endo or EMB culture medium, and do the following:

From the Endo or EMB culture medium, swab the typical coliform bacillus colony, or two or more atypical colonies, and transplant each to both a lactose broth fermentation tube and an agar slant. Cultivate for 48 hours (a 3-hour margin either way is acceptable). Perform a Gram stain procedure for the agar slant sample corresponding to the sample in which gas generation was verified, and perform a microscopic test. If gases are generated in the lactose broth fermentation tube, and the microorganisms of the colony on the agar slant are Gram-negative nonspore-forming bacilli, the conclusive test is considered positive for coliform bacilli.

#### i) Lactose broth fermentation tube:

Add lactose to ordinary broth (5 g of meat extract, 10 g of peptone, 1,000 ml of water,

pH 6.4 to 7.0); the final solution should be 0.5% lactose. Pour this solution into a number of fermentation tubes; sterilize the tubes at high pressure and cool promptly. The intermittent sterilization method may be used.

**ii) Endo culture medium:**

Heat and dissolve 3% nutrient agar (pH 7.4 to 7.8); add 15 g of lactose dissolved in a small quantity of distilled water to 1,000 ml of the agar; mix thoroughly. Add 10 ml of an ethanol-saturated solution of fuchsine (consisting of approximately 11 g of fuchsine dissolved in 100 ml of ethanol), and cool; when the solution has cooled to about 50°C, add newly prepared 10% sodium sulfite solution one drop at a time until the fuchsine turns light pink.

Pour the solution in amounts ranging from 40 to 100 ml into large test tubes and sterilize the tubes for 30 minutes at 100°C. Place about 15 ml each in several flat dishes.

**iii) EMB culture medium:**

Heat and dissolve 10 g of peptone, 2 g of dipotassium phosphate and 25 to 30 g of agar in 1,000 ml of distilled water; after boiling, replace the amount of water lost to evaporation. Add 10 g of lactose, 20 ml of a 2% aqueous solution of bromeosin and 13 ml of a 0.5% aqueous solution of methylene blue and mix; after distributing to large test tubes as before, intermittently sterilize the solution and place about 15 ml each in flat dishes.

**iv) BGLB fermentation tube:**

Dissolve 10 g of peptone and 10 g of lactose in 500 ml of distilled water; add 200 ml of fresh cow's bile (or 20 g of dried cow's bile dissolved in 200 ml of water, pH 7.0 to 7.5); add more distilled water to make approximately 975 ml of the resulting solution; adjust the pH to pH 7.4; add 13.3 ml of a 0.1% aqueous solution of brilliant green until the total volume reaches 1,000 ml; filter the solution through cotton; pour it into a number of fermentation tubes and intermittently sterilize. The pH of this solution should be between 7.1 and 7.4.

## **C-2**

When food is to be stored, no antibiotics may be used. However, this does not apply to use of additives determined by the Minister of Health, Labour and Welfare as having no potential to cause damage to human health under Article 10 of the Act.

## **C-3**

Food must not be exposed to radiation to increase storage life.

## **D. Specific Food Items**

### **D-1 Soft Drink Beverages**

#### **1. Standards for Soft Drink Beverage Components**

- (1) The beverages must not be turbid (with the exception of turbidity originating from the constituents of plants or animals used as the raw materials, from additives used for flavoring or coloring purposes, or from dead microorganisms generally recognized as being harmless to human health (but only those microorganisms that are unavoidably mixed in with the raw materials of the products)).
- (2) The beverages must not contain any sediment (with the exception of sediment originating from plant or animal constituents used as raw materials, from additives used for flavoring or coloring purposes, or from dead microorganisms generally recognized as being harmless to human health (but only those microorganisms that are unavoidably mixed in with the raw product materials)) or any solid foreign matter (with the exception of solid plant matter used as raw materials whose volume percentage is less than 30%).
- (3) The beverage must not contain detectable levels of arsenic, lead, or cadmium. The tin content must not exceed 150.0 ppm.

The following test method is used to test for arsenic, lead, cadmium and tin.

##### **a. Preparation of sample solutions**

The sample solution is prepared by the wet degradation method described in i) below or the dry incineration method described in ii) below. However, in testing for arsenic, only the wet degradation method described in a. below may be used.

##### **i) Wet degradation method:**

Prepare a 100 g test sample (for a soft drink beverage that is diluted for drinking, use an amount equal to that obtained by dividing 100 g by the multiple by which the beverage is to be diluted; for a concentrated fruit juice, use the amount obtained by dividing 100 g by the multiple by which the original juice was concentrated); heat on a water bath, and concentrate by evaporation until the sample turns into a syrup. Using about 10 ml of water, transfer the syrup to a decomposition flask, add and dissolve 8 ml of sulfuric acid and 10 ml of nitric acid, and while heating the solution, add nitric acid, 1 to 2 ml at a time, until the solution turns essentially colorless or light yellow. Cool the solution, and once it has cooled, add 15 ml of water and 10 ml of ammonium oxalate solution, and heat until a white smoke appears around the neck of the flask. After cooling, add water to total 50 ml, and use this as the sample solution. Using water instead of the test sample, prepare a blank sample solution following the same steps.

**ii) Dry incineration method**

In a dehydrator or under an infrared lamp, dry a 50 g test specimen (for a soft drink beverage that is diluted for drinking, use an amount equal to that obtained by dividing 50 g by the multiple by which the beverage is to be diluted; for a concentrated fruit juice, use the amount obtained by dividing 50 g by the multiple by which the original juice was concentrated) and heat it at 450 to 500°C until a nearly white ash is obtained. After cooling, gently add 5 ml of hydrochloric acid (1 → 2) and dissolve the ash-like material. Heat in a water bath until the liquid evaporates. After cooling, add enough 1 mol/l hydrochloric acid to dissolve the ash and make 25 ml, and use this as the sample solution. Using water instead of the test specimen, prepare a blank sample solution following the same steps.

**b. Test methods for arsenic**

Arsenic is tested using the Gutzeit method as described in i) below or the silver diethyldithiocarbamate method as described in ii) below.

**i) Gutzeit method**

When testing a 3 ml sample solution for arsenic using equipment A in the arsenic test methods described in Part II: Additives, Section B: General Testing Methods, the color of the sample solution should not be darker than the standard color. The standard color is established by following the same steps as for the sample solution with a solution obtained by adding 1.2 ml of the standard arsenic solution to 3 ml of the blank sample solution.

## ii) Silver diethyldithiocarbamate method

### <1> Equipment

An overview of the equipment is provided in the next figure (unit: mm).

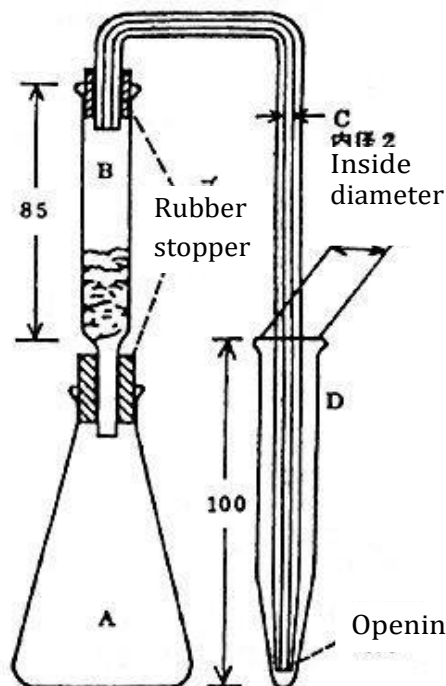

A: Generation flask (with a 100 to 125 ml internal capacity)

B: Absorption tube (packed with glass wool moistened with a lead acetate solution)

C: Gas guidance tube

D: Absorption receiver

### <2> Agents and reagents

Use agents and reagents listed in Part II: Additives, Section C: Reagents and Solutions in most cases. Exceptions are listed below.

- Silver diethyldithiocarbamate pyridine solution: Dissolve 1 g of silver diethyldithiocarbamate into 200 ml of pyridine, protect from it the light, and keep it in a cool place.
- Arenaceous zinc: Soak 20 to 30-mesh zinc without arsenic in a 1% solution of copper sulfate until it turns black; wash, and then dry.
- Tin chloride: Dissolve 4 g of tin chloride into 125 ml of zinc without arsenic hydrochloric acid and add water until the total volume equals 250 ml; pour into a stoppered bottle, seal, and store.

### <3> Test procedure

Place 10 ml of the sample solution into the generation flask and add water until the total volume equals 25 ml; add 5 ml of hydrochloric acid (1 → 2), 2 ml of potassium iodide solution and 5 ml of tin chloride solution and leave standing at room temperature for 15 minutes. Next, add 3 g of arenaceous zinc to the generation flask; immediately connect the absorption and gas guidance tubes;

place in an absorption receiver that already contains 3 ml of the silver diethyldithiocarbamate pyridine solution; leave standing for one hour at 20 to 25°C. Disconnect the equipment, and after thoroughly mixing the solution in the gas guidance tube with the absorption solution in the absorption receiver, place the absorption solution in a 1 cm absorption cell. Within 30 minutes, measure the absorbency using a wavelength in the vicinity of 525 nm, with the silver diethyldithiocarbamate pyridine solution as a reference. The absorbency of the sample solution thus measured must not exceed the absorbency that is obtained by following the same steps with 10 ml of the blank sample solution to which 4 ml of a standard arsenic solution and water have been added to equal 25 ml.

### **c. Test methods for lead and cadmium**

Lead and cadmium are tested using atomic absorption spectrophotometry as described in i) below or polarographic analysis as described in ii) below.

#### **i) Atomic absorption spectrophotometry**

##### **<1> Equipment**

Atomic absorption spectrophotometer

- Light source: A lead hollow cathode lamp to test for lead; a cadmium hollow cathode lamp to test for cadmium
- Fuel: Acetylene gas or hydrogen

##### **<2> Agents and reagents**

Use agents and reagents listed in Part II: Additives, Section C: Reagents and Solutions in most cases. Exceptions are listed below.

- Ammonium citrate solution: Dissolve 2.5 g of diammonium citrate in water to total 100 ml.
- Ammonium sulfate solution: Dissolve 40 g of ammonium sulfate in water to total 100 ml.
- DDTC solution: Dissolve 10 g of sodium diethyldithiocarbamate in water to total 100 ml.
- Lead control solution: Dissolve 1.598 g of lead nitrate in 1 mol/l nitric acid to total 1,000 ml. Take 8 ml of this solution and add 0.5 mol/l nitric acid to total 1,000 ml.
- Cadmium control solution: Add 100 ml of 1 mol/l nitric acid to 1.000 g of metal cadmium and dissolve by heating. After cooling, add 1 mol/l nitric acid to total 1,000 ml. Take 2 ml of this solution and add 0.5 mol/l nitric acid to total 1,000 ml.

##### **<3> Test procedure**

Take 10 ml each of the sample solution and blank sample solution, add 2 ml of ammonium citrate and 2 drops of bromothymol blue reagent to each; neutralize using ammonia water until the solution turns from yellow to green; add 2 ml of the ammonium sulfate solution to each and add water to total 20 ml. Next, add 2

ml of the DDTTC solution to each and mix; let stand for several minutes, add 10 ml of methyl isobutyl ketone and shake vigorously. Let the solutions stand, then remove the methyl isobutyl ketone layer. Measure the absorbency  $A$  of the sample solution and the absorbency  $A_b$  of the blank sample solution at a measurement wavelength of 217.0 nm for the lead test and of 228.8 nm for the cadmium test. Take 1 ml of the lead control solution or 1 ml of the cadmium control solution and 1 ml of water; add 0.5 mol/l nitric acid to each to total 10 ml and measure absorbency. Determine the absorbency  $A_s$  of the control solution and absorbency  $A_o$  of the water following the same steps as with the sample solutions. The value of  $A-A_b$  thus obtained must not exceed  $A_s-A_o$ .

## ii) Polarographic analysis

### <1> Agents and reagents

Use agents and reagents listed in Part II: Additives, Section C: Reagents and Solutions in most cases. Exceptions are listed below.

- First electrolyte solution: Mix equal quantities of 1.2 Mol/l perchloric acid and 0.004 mol/l hydrochloric acid.
- Second electrolyte solution: Mix equal quantities of 0.6 mol/l perchloric acid and 0.002 mol/l hydrochloric acid.
- Gelatin solution: Add 100 mg of gelatin to 100 ml of water, heat and dissolve.
- Lead or cadmium control solution: Add 1 ml of nitric acid (1 → 100) to 0.1598 g of lead nitrate; add 10 ml of water to make a solution and then add 50 ml of the first electrolyte solution. Add water to total 100 ml; use this as the lead control solution. Next, add 5 ml of hydrochloric acid (1 → 2) and approximately 5 ml of water to 0.250 g of metal cadmium; heat and dissolve; cool; then add 1 mol/l hydrochloric acid to total 250 ml. To 10 ml of this solution, add 50 ml of the first electrolyte solution; add water to total 100 ml, and use this as the cadmium control solution.
- Add the first electrolyte solution to 0.8 ml of the lead control solution and 2 ml of the cadmium control solution to total 100 ml. Take 10 ml of this solution, and add the first electrolyte solution to total 100 ml.
- Hydrobromic acid reagent: Use hydrobromic acid (special grade)

### <2> Test procedure

Mix 5 ml of the sample solution with 5 ml of the first electrolyte solution (when using a DC polarograph, also add 0.2 ml of the gelatin solution). However, when tin is also present in the sample solution, first evaporate 5 ml of the sample solution to dryness on a sand bath; add 10 ml of a hydrobromic acid sample solution, and evaporate again to dryness. After cooling, add 5 ml of the hydrobromic acid sample solution; evaporate again to dryness; gently pour 5 ml of hydrochloric acid (1 → 2); evaporate again to dryness in a sand bath. Add 10 ml of the second electrolyte solution to the residue (when using a DC polarograph, also add 0.2 ml of the gelatin solution); let stand for at least 3 hours, mixing occasionally. Place approximately 5 ml of this solution in an

electrolysis jar; add mercury until the jar's platinum wire is no longer visible; place the solution in a 25°C constant-temperature water bath, and insert a dropping mercury electrode. Next, pass nitrogen through the electrolysis jar for 15 minutes and record a polarograph between -0.3 and -1.0V. The peak for the sample solution must not exceed the peak obtained by following the same steps with 5 ml of the blank sample solution to which 5 ml of the cadmium control solution has been added.

#### **d. Test methods for tin**

Tin is tested using the salicylidenamino-2-thiophenol method as described in i) below or by polarographic analysis method as described in ii) below.

##### **i) Salicylidenamino-2-thiophenol method**

###### **<1> Agents and reagents**

Use agents and reagents listed in Part II: Additives, Section C: Reagents and Solutions in most cases. Exceptions are listed below.

- SATP solution: Dissolve 1 g of L-ascorbic acid in a small amount of water and add ethanol to total 100 ml. Add 0.1 g of salicylidenamino-2-thiophenol to this solution and heat to dissolve.
- Dinitrophenol solution: Add 0.25 g of 2, 4-dinitrophenol to 100 ml of 50% ethanol, and dissolve.
- Lactic acid solution: Add water to 20 ml of lactic acid (special grade) to total 100 ml.
- Tin control solution: Add 30 ml of hydrochloric acid to 0.500 g of metal tin, and heat on a water bath to dissolve. After cooling, add 1 ml of 30% hydrogen peroxide water, and add 1 mol/l hydrochloric acid to total 500 ml. Take 1 ml of this solution and add 1 mol/l hydrochloric acid to total 100 ml. One ml of this solution contains 10 µg of tin.
- Sodium hydroxide solution: Dissolve 10 g of sodium hydroxide in water to total 100 ml.
- Sodium thiosulfate solution: Dissolve 1 g of sodium thiosulfate in water to total 100 ml.

###### **<2> Test procedure**

Take 1 ml of the sample solution and add 1 mol/l hydrochloric acid to total 10 ml. To 1 ml of this solution, add 1 mol/l hydrochloric acid to total 10 ml; add two drops of the dinitrophenol solution. Add enough sodium hydroxide solution to neutralize and add water to total 20 ml. Next, add 2 ml of the lactic acid solution, 1 ml of the sodium thiosulfate solution and 5 ml of the SATP solution and mix; let stand for 20 minutes, add 10 ml of xylene and shake vigorously. Using the xylene layer as a control, measure absorbency at about the 415nm wavelength. Determine the amount of tin in the sample solution using an analytical curve; use this to calculate the concentration of tin in the test specimen.

<3> Plotting an analytical curve

An analytical curve is plotted as follows. First, take 0, 1.0, 2.0, 3.0, 4.0 and 5.0 ml of the tin control solution, and to each of these add 1 ml of a solution made by taking 1 ml of the blank sample solution and adding 1 mol/l hydrochloric acid to total 10 ml. Add 1 mol/l hydrochloric acid to total 10 ml. Next, add two drops of the dinitrophenol solution; hereafter, follow the same steps as for the sample solution. Measure the absorbency of each solution and plot the curve.

**ii) Polarographic analysis**

<1> Agents and reagents

Use agents and reagents listed in Part II: Additives, Section C: Reagents and Solutions in most cases. Exceptions are listed below.

- First electrolyte solution: Mix equal quantities of 4 mol/l ammonium chloride solution and 4 mol/l hydrochloric acid.
- Second electrolyte solution: Mix equal quantities of 2 mol/l ammonium chloride solution and 2 mol/l hydrochloric acid.
- Tin control solution: Add 40 ml of hydrochloric acid to 0.500 g of metal tin and heat on a water bath to dissolve; add hydrochloric acid to total 250 ml. Take 10 ml of this solution, and add the second electrolyte solution to total 100 ml. One ml of this solution contains 200 µg of tin.

<2> Test procedure

Take 1 ml of the sample solution and mix it with 5 ml of the first electrolyte solution; add water to total 10 ml. Place approximately 5 ml of this solution in an electrolysis jar; add mercury until the jar's platinum wire is no longer visible; place the solution in a 25°C constant-temperature water bath, and insert a dropping mercury electrode. Next, pass nitrogen through the electrolysis jar for 15 minutes and record a polarograph between -0.3 and -0.7 V. Measure the peak; obtain the amount of tin in the sample solution using an analytical curve; calculate the concentration of tin in the test specimen.

<3> Plotting an analytical curve

An analytical curve is plotted as follows. First, take 0, 0.5, 1.0, 1.5, 2.0 and 2.5 ml of the tin control solution, add 1 ml of the blank sample solution and 5 ml of the first electrolyte solution to each and mix; add water to total 10 ml. Hereafter, follow the same steps as for the sample solution, measure the peaks and plot the curve.

**(4) Tests for coliform bacilli must be negative.**

The method used to test for coliform bacilli is as follows.

**a. Collecting the test specimens and preparing the samples**

Use test specimens that are still in their containers; wash the outside of the containers briefly

under running water and dry. Use cotton dipped in alcohol (defined as cotton dipped in 70% ethanol; hereafter the same) to wipe around the areas to be tested; use a sterilized implement to unseal the containers; open the containers and take 10 ml and 1 ml of the solution as well as 1 ml of a 10x solution and use these as sample solutions. For soft drink beverages containing carbonic acid, first transfer the specimen to another sterilized container, stir and let stand until the carbon dioxide disperses; then follow the step above to make sample solutions.

#### **b. Coliform bacilli test method**

The method used is that described in Part I: Foodstuffs, Section B: General Food Storage Standards, Paragraph 1, Sub-paragraph (2): Coliform Bacilli Test Method.

(5) Mineral water (defined as a soft drink beverage whose basic material consists solely of water; hereafter the same) with a carbon dioxide pressure inside the container of not more than 98 kPa at 20°C, and that has not been sterilized or disinfected, must test negative for enterococci or green pus bacilli.

The following method is used to test for enterococci or green pus bacilli in such beverages:

#### **a. Collecting the test specimens and preparing the samples**

Use test specimens in unopened containers; use cotton dipped in alcohol to wipe around the test areas; use a sterilized implement to unseal or open the containers; take 10 ml and 1 ml of the solution; use these as the samples.

#### **b. Enterococci test method**

##### **i) Presumptive test:**

Inoculate both the 10 ml and 1 ml samples into AC culture medium.

When inoculating the 10 ml sample, use 10 ml of double-concentration AC culture medium. After cultivating the samples for 48 +/-3 hours at 35.0 +/-1.0°C, inspect for turbidity. If turbidity has occurred, the presumptive test is considered positive.

##### **ii) Confirmation test:**

Using a platinum loop, transplant a sample from the test tube yielding positive results in the preliminary test to a new AC culture medium; cultivate the samples for 48 +/-3 hours at 45.0 +/-1.0°C and inspect for turbidity. If turbidity has occurred, the confirmation test is considered positive.

##### **iii) Conclusive test:**

Use a platinum loop to make a streak culture from the test tube yielding positive results in the preliminary test in a glucose agar medium, and cultivate an independent colony. After cultivation for 24 +/-2 hours at 35.0 +/-1.0°C, swab the independent colony and transfer it to a glucose broth; cultivate it for 24 +/-2 hours at 35.0 +/-1.0°C. Transfer samples of the colony to a glucose agar slant and a 6.5% sodium chloride-added glucose broth, and cultivate at 35.0 +/-1.0°C. After cultivating for 24 +/-2 hours on the glucose agar slant, perform a catalase test on the bacilli that develop. If any bacilli yield negative results in the catalase test, perform a Gram stain

procedure, and a microscopic test. After cultivation for 48 +/-3 hours in the 6.5% sodium chloride-added glucose broth, inspect for turbidity. If the bacilli on the glucose agar slant are Gram-negative cocci and the samples show turbidity in the 6.5% sodium chloride-added glucose broth, the conclusive test is considered positive for coliform bacilli.

<1> AC culture medium:

Dissolve 20 g of peptone, 5 g of yeast extract, 5 g of glucose, 10 g of sodium citrate, 5 g of sodium chloride, 4 g of dipotassium phosphate, 1.5 g of monobasic potassium phosphate and 0.25 g of sodium azide in 1,000 ml of purified water; sterilize the solution and adjust the pH to 7.0. Pour some of the solution into a test tube, and sterilize for 15 minutes at 121°C.

<2> Glucose agar medium:

Heat and dissolve 10 g of peptone, 3 g of yeast extract, 10 g of glucose, 5 g of sodium chloride and 15 g of agar in 1,000 ml of purified water; sterilize the solution and adjust the pH to 7.4. Sterilize for 15 minutes at 121°C.

<3> Glucose broth:

Dissolve 10 g of peptone, 5 g of meat extract, 10 g of glucose and 5 g of sodium chloride in 1,000 ml of purified water; sterilize the solution; adjust the pH to 7.0; pour some of the solution into a test tube, and sterilize for 15 minutes at 121°C.

<4> Glucose agar slant:

Heat and dissolve 10 g of peptone, 3 g of yeast extract, 5 g of glucose, 5 g of sodium chloride and 13 g of agar in 1,000 ml of purified water; sterilize the solution; adjust the pH to 7.4; pour some of the solution into a test tube, and sterilize for 15 minutes at 121°C.

<5> 6.5% sodium chloride-added glucose broth:

Dissolve 10 g of peptone, 5 g of meat extract, 10 g of glucose and 65 g of sodium chloride in 1,000 ml of purified water; sterilize the solution; adjust the pH to 7.0; pour some of the solution into a test tube, and sterilize for 15 minutes at 121°C.

**a. Green pus bacilli test method**

**i) Presumptive test:**

Inoculate the 10 ml and 1 ml samples into separate containers of asparagine broth. When inoculating the 10 ml sample, use 10 ml of the asparagine broth at double the concentration. After cultivating the sample for 24 +/-2 hours at 35 +/-1°C, inspect for turbidity and also for fluorescence under an ultraviolet lamp with a long wavelength (365 nm). If turbidity or fluorescence is not found, continue the cultivation and observe up to 48 +/-3 hours. If turbidity or fluorescence is found, this is considered positive for the presumptive test.

**ii) Confirmation test:**

Using a platinum loop, prepare a streak culture on a ceftrimide agar medium using samples from the test tube yielding a positive result in the presumptive test, and cultivate independent colonies. After cultivating the colonies for 48 +/-3 hours at 35 +/-1°C, swab the colonies that are green or reddish-brown in color, and transplant them to a regular agar slant. After cultivating the colonies for 24 +/-2 hours at 41.5 +/-0.5°C, observe whether bacilli have grown, and if they have, conduct an oxidase test. If a positive result is yielded in the oxidase test, perform a Gram stain procedure, and examine the results under a microscope. If the bacilli are Gram-negative nonspore-forming bacilli, the sample is considered positive for green pus bacilli.

<1> Asparagine broth:

Dissolve 3 g of DL-asparagine, 1 g of dipotassium phosphate and 0.5 g of magnesium sulfate in 1,000 ml of purified water, and after sterilizing the solution, adjust the pH to 6.9 to 7.2. Then pour part of the solution into a test tube, and sterilize for 15 minutes at 121°C.

<2> Ceftrimide agar medium:

Heat and dissolve 20 g of peptone, 1.4 g of magnesium chloride, 10 g of magnesium sulfate, 0.3 g of ceftrimide and 15 g of agar in 1,000 ml of purified water. After sterilizing the solution, adjust the pH to 7.0 to 7.4, and sterilize for 15 minutes at 121°C.

(6) For beverages made solely of apple juices and/or juiced fruit, the patulin content must not exceed 0.050 ppm.

Use either the patulin test method described below or a test method recognized as having an equivalent or superior performance to test patulin content.

**a. Equipment**

A high-speed liquid chromatograph equipped with an ultraviolet spectrophotometer detector and a liquid chromatograph/mass spectrometer, or a gas chromatograph/mass spectrometer should be used.

**b. Agents and reagents**

Use agents and reagents listed in Part I: Foodstuff, Section C: Specific Food Items, Sub-section C17: Grains, Beans and Vegetables, Paragraph 2: Test Methods for Standards for Grains and Beans Component, Sub-paragraph (2): Agents and reagents in most cases. Exceptions are listed below.

- Trimethylsilyl agent: Add ethyl acetate to 0.5 ml of N, O-bis (trimethylsilyl) trifluoroacetamide to total 20 ml.
- Patulin control solution: Add ethyl acetate or acetonitrile to patulin, dissolve and prepare.

### **c. Standard product**

- Patulin: This product contains more than 98% patulin.
- Melting point: The melting point of this product is 110 to 111°C.

### **d. Preparation of sample solution**

#### **i) Extraction**

Put 5 g of a test specimen (for a soft drink beverage that is diluted for consumption, this means a beverage that has been diluted with water by the prescribed percentage and is ready for consumption; for a concentrated fruit juice, it means reconstituting the juice to its original concentration) into a 30 to 50 ml test tube with a stopper, and add 10 ml of ethyl acetate. After shaking vigorously for one minute, let the solution stand, and then transfer the ethyl acetate layer to another 30 to 50 ml test tube with stopper. Add 10 ml of ethyl acetate to the water layer in the original test tube and repeat the above process, removing the ethyl acetate layer to the second test tube. Repeat the entire process again.

#### **ii) Purification**

Add 2 ml of a 1.5% sodium carbonate solution to the solution extracted to the second test tube above i, and shake it vigorously for 10 to 20 seconds. Using a solution layer liquid-phase separation filter paper or a funnel in which about 10 g of sodium sulfate has been placed, filter the ethyl acetate layer into a vacuum concentrator. Add 5 ml of ethyl acetate to the remaining sodium carbonate layer, and after shaking vigorously for 30 seconds, perform the same operations as above. Combine the filtrate with that already in the vacuum concentrator, and concentrate to about 2 ml at less than 40°C. Transfer to a glass test tube or vial. Next, wash the vacuum concentrator using a small amount of ethyl acetate, repeat the operations in which the filtrates are combined three times, and remove the ethyl acetate under a nitrogen air flow at less than 40°C. Add 1.0 ml of an ethyl acetate solution (pH 3.6 to 4.0) to the residue and dissolve, and after shaking vigorously, filter using a 0.45 µm membrane filter. This is the sample solution.

To use as a sample solution in the gas chromatograph/mass spectrometer, add 0.5 ml of the trimethylsilyl agent to the above residue, put the stopper in place, and after shaking, leave standing for 60 minutes at room temperature.

### **e. Testing procedure**

#### **i) Qualitative test**

Using a high-speed liquid chromatograph equipped with an ultraviolet spectrophotometer-type detector, perform the test under the following operating conditions. The test results must tally with the patulin control solution.

#### **Operating conditions**

- Column filler: An octadecylsilyl silica gel (with a particle size of 5 µm) from the silanol group, which has been completely end-capped, must be used.
- Column tube: A stainless steel tube with an inside diameter of 4.0 to 4.6 mm

and a length of 250 mm must be used.

- Column temperature: 40°C
- Detector: This must be operated on a wavelength of 276 or 290 nm.
- Moving phase: A mixed solution of acetonitrile and water (ratio of 4:96) must be used. Adjust the flow rate so that the patulin will flow out in about 14 minutes.

### ii) Quantitative test

Based on the test results yielded under the same test conditions as the qualitative test i, perform a quantitative test using the peak height method or peak area method.

### iii) Verification test

<1>When performing the test using a high-speed liquid chromatograph/mass spectrometer:

Proceed with the liquid chromatograph/mass spectrometer analysis under the same test conditions as the qualitative test i). The test results must tally with the patulin control solution. If necessary, perform a quantitative test using the peak height method or peak area method.

<2> When performing the test using a gas chromatograph/mass spectrometer:

Perform the test under the following test conditions. With regard to the patulin control solution, the test results must tally with those obtained performing the same operations as with the sample solution used for the gas chromatograph/mass spectrometer analysis in Paragraph 4: Preparation of sample solution. If necessary, perform a quantitative test using the peak height method or peak area method.

#### Test conditions

- Column: A thin tube made of silicate glass with an inside diameter of 0.22 to 0.25 mm and a length of 25 to 30 mm, and coated with 35% phenyl polysilphenylenesiloxane used for gas chromatography to a thickness of 0.25 to 1.5 µm, must be used.
- Column temperature: Temperature must be maintained for 2 minutes at 80°C, after which it must be raised by 10°C per minute. After it has reached 150°C, it must be raised by 5°C per minute, and after it has reached 230°C, it must be maintained for 15 minutes.
- Temperature of inlet through which sample solution is poured: 230°C
- Pouring method: No splits
- Detector: Must operate at 230°C.
- Gas flow rate: Helium must be used as the carrier gas. Adjust the flow rate so that the patulin will flow out in about 14 minutes.

## 2. Production Standards for Soft Drink Beverages

(1) Soft drink beverages other than mineral water, frozen fruit juice drinks (defined as frozen fruit juices or frozen concentrates of fruit juices and not the original juices of the fruits from which these beverages are made; hereafter the same), and soft drink beverages other than fruit juices used as raw materials for such.

a. The fruits, vegetables and other raw materials used in the production of soft drink beverages must be fresh and other quality aspects must be excellent. Furthermore they must be thoroughly washed if necessary.

b. The water used as the raw material must be water that is potable (defined as water supplied from a water supply for water supply businesses as stipulated in Section 2 Article 3 of the Water Supply Law (No.177, 1957); water supplied from a dedicated water-supply system as specified in Section 6 of the same article; water supplied from a small dedicated water-supply system as specified in Section 7 of the same article; or water that is found to be compliant with the standards listed in Col. 2 of the table below by an inspection for the elements listed in Col. 1 using a method listed in Col. 2 of the same table; hereafter the same).

Column 1	Column 2	Column 3
Non-specific microorganisms	The number of colonies formed in 1 ml of the test water must be 100 or less.	Standard agar media method
Coliform bacilli	Must be not be detected.	Lactose broth/brilliant green lactose bile broth method
Cadmium	Must be 0.01 mg/1 or less.	Flameless atomic absorption spectrometry or inductively coupled plasma emission spectroscopic analysis (hereafter the "ICP method")
Mercury	Must be 0.0005 mg/1 or less.	Reduction vaporization/atomic absorption spectrometry
Lead	Must be 0.1 mg/1 or less.	Flameless atomic absorption spectrometry or ICP method
Arsenic	Must be 0.05 mg/1 or less.	Hydride generation/atomic absorption spectrometry or flameless atomic absorption spectrometry
Hexavalent chromium	Must be 0.05 mg/1 or less.	Flameless atomic absorption spectrophotometry or ICP method
Cyanide	Must be 0.01 mg/1 or less.	Absorption spectrophotometry
Nitrate nitrogen and nitrite nitrogen	Must be 10 mg/1 or less.	Ion chromatography or absorption spectrophotometry

Fluorine	Must be 0.8 mg/1 or less	Ion chromatography or absorption spectrophotometry
Organophosphorus	Must be 0.1 mg/1 or less.	Absorption spectrophotometry
Zinc	Must be 0.1 mg/1 or less.	Flameless atomic absorption spectrophotometry or ICP method
Iron	Must be 0.3 mg/1 or less.	Flameless atomic absorption spectrophotometry, ICP method or absorption spectrophotometry
Copper	Must be 1.0 mg/1 or less.	Flameless atomic absorption spectrophotometry or ICP method
Manganese	Must be 0.3 mg/1 or less.	Flameless atomic absorption spectrophotometry or ICP method
Chlorine ions	Must be 200 mg/1 or less.	Ion chromatography or titration
Calcium, magnesium, etc. (hardness)	Must be 300 mg/1 or less.	Titration
Evaporation residues	Must be 500 mg/1 or less.	Gravimetric method
Anionic surface active agents	Must be 0.5 mg/1 or less.	Absorption spectrophotometry
Phenols	Must be 0.005 mg/1 or less as phenol.	Absorption spectrophotometry
Organic matter (in terms of the amount of potassium permanganate consumed)	Must be 10 mg/1 or less.	Titration
pH level	Must be within the 5.8 to 8.6 range.	Glass electrode method or colorimetric method
Taste	Must not be abnormal.	Sensory method
Odor	Must not be abnormal.	Sensory method
Chromaticity	Must be 5 degrees or less.	Colorimetric method or transmitted light measurement method
Turbidity	Must be 2 degrees or less.	Turbimetry, transmitted light measurement method or integrating-sphere electrophotometry

**c. The instruments to be used for production and the container packages must be washed using an appropriate method and also sterilized. However, this shall not apply to unused container packages that have been sterilized, or produced in a way that imparts a sterilizing effect, and that have been handled in a manner that precludes contamination before use.**

**d. Soft drink beverages must be either filled in the container packages and completely stoppered or sealed and then sterilized, or they must first be sterilized by a pasteurizer or other such unit equipped with a thermograph or first disinfected by a filter or other such unit and then filled automatically in the container packages, and after this must be completely stoppered or sealed. The following method shall be used for sterilization or disinfection. However, sterilization or disinfection is not required for soft drink beverages that have a carbon dioxide pressure inside the container packages of more than 98 kPa at 20°C and that do not contain any plant or animal components.**

- i) Soft drink beverages with a pH of less than 4.0 must be sterilized by a method that heats the center for 10 minutes at a temperature 65°C or by a method of equal or better efficacy.
- ii) Soft drink beverages with a pH or 4.0 or more (excluding soft drink beverages with pH 4.6 or more and a water activity in excess of 0.94) must be sterilized by a method that heats the center for 30 minutes at a temperature 85°C or by a method of equal or better efficacy.
- iii) Soft drink beverages with a pH or 4.6 or more and a water activity in excess of 0.94 must be sterilized by a method effective enough to destroy the microorganisms that originate in the raw materials, etc. and are present in the foods concerned, and that may possibly grow or by a method specified in "b" above.
- iv) Soft drink beverages must be disinfected by a method effective enough to remove the microorganisms that originate in the raw materials, etc. and are present in the foods concerned, and that may possibly grow.

**e. Records of the sterilization temperatures and sterilization times applicable to the sterilization processes described in d. and records relating to the disinfection also described in d. must be kept for six months.**

**f. When soft drink beverages are to be capped with paper tops, it must be done by capping machines.**

**(2) Mineral waters**

**a. The water used as the raw material must be water supplied from a water supply for water supply businesses as stipulated in Section 2 Article 3 of the Water Supply Law, water supplied from a dedicated water-supply system as specified in Section 6 of the same article, water from a small dedicated water-supply system as specified in Section 7 of the same article, or water that is found to be compliant with the standards listed in Col. 2 of the table below by the inspection for the elements listed in Col. 1 using a method listed in Col. 3 of the same table.**

<b>Column 1</b>	<b>Column 2</b>	<b>Column 3</b>
Non-specific microorganisms	The number of colonies formed in 1 ml of the test water must be 100 or less.	Standard agar media method
Coliform bacilli	Amount must be undetectable.	Lactose broth/brilliant green lactose bile broth method
Cadmium	Must be 0.01 mg/1 or less.	Flameless atomic absorption spectrometry or the ICP method
Mercury	Must be 0.0005 mg/1 or less.	Reduction vaporization/atomic absorption spectrometry
Selenium	Must be 0.01 mg/1 or less.	Hydride generation/atomic absorption spectrometry or flameless atomic absorption spectrometry
Lead	Must be 0.05 mg/1 or less.	Flameless atomic absorption spectrometry or ICP method
Barium	Must be 1 mg/1 or less.	Flameless atomic absorption spectrometry or ICP method
Arsenic	Must be 0.05 mg/1 or less.	Hydride generation/atomic absorption spectrometry or flameless atomic absorption spectrometry
Hexavalent chromium	Must be 0.05 mg/1 or less.	Flameless atomic absorption spectrophotometry or ICP method
Cyanide	Must be 0.01 mg/1 or less.	Absorption spectrophotometry
Nitrate nitrogen and nitrite nitrogen	Must be 10 mg/1 or less.	Ion chromatography or absorption spectrophotometry
Fluorine	Must be 2 mg/1 or less.	Ion chromatography or absorption spectrophotometry
Boron	Must be 30 mg/1 or less as boric acid.	ICP method or absorption spectrophotometry
Zinc	Must be 5 mg/1 or less.	Flameless atomic absorption spectrophotometry or ICP method
Copper	Must be 1 mg/1 or less.	Flameless atomic absorption spectrophotometry or ICP method
Manganese	Must be 2 mg/1 or less.	Flameless atomic absorption spectrophotometry or ICP method
Organic matter	Must be 12 mg/1 or less in terms of the amount of potassium permanganate consumed	Titration
Sulfides	Must be 0.05 mg/1 or less as hydrogen sulfide	Absorption spectrophotometry

- b. The instruments to be used for production and the container packages must be washed using an appropriate method and then sterilized. However, this shall not apply to unused container packages that have been previously sterilized or produced in a way that imparts a sterilizing effect, and that have been handled in a manner that precludes contamination before use.**
- c. The containers should either first be filled with mineral water, completely stoppered or sealed and then sterilized; or they must first be sterilized by a pasteurizer or other such unit equipped with a thermograph or disinfected by a filter or other such unit and then filled automatically, and after this must be completely stoppered or sealed. They must be sterilized or disinfected to this end by a method that heats the center for 30 minutes at a temperature 85°C or by another method effective enough to destroy or remove the microorganisms that originate in the water or other raw materials and are present in the foods concerned and that may possibly grow. However, sterilization or disinfection is not required for mineral waters that have a carbon dioxide pressure inside the container of more than 98 kPa at 20°C or that are produced by a method complying with the following standard.**
- i) The water used as the raw material must be mineral water only, and after automatically filling the container with water taken directly from the spring source, it must be completely stoppered or sealed.
  - ii) The water used as the raw material must not be contaminated with pathogenic microbes, or contain organisms or substances that Could cause the water to be suspected of being contaminated with pathogenic microbes.
  - iii) The water used as the raw material must test negative for anaerobic sulfite-reducing sporeforming bacilli, enterococci and green pus bacilli, and the bacterial count per 1 ml must be 5 or less. The following methods shall be used to test for anaerobic sulfite-reducing sporeforming bacilli, enterococci, green pus bacilli and to determine the bacterial count.

<1> Collecting the test specimens and preparing the samples

Using a sterilized sampling instrument, aseptically collect a sample of the water used as the raw material and place it in a sterilized container for each test and count determination. This is the test specimen. After pouring 250 ml (or 100 ml to determine the bacterial count) of the test specimen (which, for the anaerobic sulfite-reducing sporeforming bacilli tests, must be heat-treated for 20 minutes at 70°C) into the funnel of a membrane filter unit and after suction filtration, wash the inside of the funnel two or three times using 20 to 30 ml of sterilized purified water before suction filtering again. After filtration, use sterilized tweezers to peel the membrane filter from the filter holder, and use this as the sample.

Membrane filter unit: Use a unit whose funnel and filter holder have been

sterilized for 15 minutes at 121°C, and a 0.45 µm membrane filter (or 0.22 µm for testing for anaerobic sulfite-reducing sporeforming bacilli), and that has been sterilized ahead of time and washed in sterilized purified water.

<2> Anaerobic sulfite-reducing sporeforming bacilli test method

Tightly adhere the samples on an agar medium containing sulfite and ferrous in such a way that no air is included, and cultivate anaerobically for 48 +/-3 hours at 35.0 +/-1°C. Those samples on which black colonies grow are considered positive for anaerobic sulfite-reducing sporeforming bacilli.

Agar medium containing sulfite and ferrous: For every 18 ml of the nutrient agar, add 1 ml of sodium sulfite solution (produced by dissolving 10 g of sodium sulfite in 100 ml of purified water) and 5 drops of ferrous sulfate solution (produced by dissolving 8 g of ferrous sulfate in 100 ml of purified water) to the nutrient agar immediately before plate preparation.

<3> Coliform bacilli test method

<a> Presumptive test: Tightly adhere the samples on a KF-chain coccus agar medium in such a way that no air is included, and cultivate for 48 +/-3 hours at 35.0 +/-1°C. Those samples on which light crimson to red colonies grow are considered positive for the presumptive test.

<b> Confirmation test: Swab the light crimson to red colonies and culture on a bile/esculin/azide agar medium until independent colonies are generated. After cultivating for 48 +/-3 hours at 45.0 +/-1.0°C, swab the other to black colonies, and transplant them to a glucose agar slant. After cultivation for 24 +/-2 hours at 35.0 +/-1.0°C, conduct a catalase test on the colonies that develop. For colonies yielding negative results in the catalase test, perform a Gram stain procedure, and examine under a microscope. If the colonies are Gram-positive cocci, the confirmation test is considered positive for coliform bacilli.

KF-chain coccus agar medium: Heat and dissolve 10 g of peptone, 10 g of yeast extract, 5 g of sodium chloride, 10 g of sodium glycerophosphate, 20 g of maltose, 1 g of lactose, 0.4 g of sodium azide, 1 ml of bromocresol purple solution (produced by dissolving 15 g of bromocresol purple in 1,000 ml of ethanol) and 15 g of agar in 1,000 ml of purified water, and after boiling for 5 minutes, cool until the temperature drops to between 50 and 60°C. After adding 10 ml of pre-prepared TTC solution (produced by dissolving 1 g of 2, 3, 5-triphenyltetrazolium chloride in 100 ml of purified water and filtering through a 0.45 µm membrane filter), adjust the pH to 7.2.

Bile/esculin/azide agar medium: Heat and dissolve 20 g of peptone, 5 g of yeast extract, 10 g of powdered cow's bile, 5 g of sodium chloride, 1 g of esculin, 0.5 g of ferric ammonium citrate, 0.15 g of sodium azide and 15 g of

agar in 1,000 ml of purified water, and after sterilizing, adjust the pH to 7.0 to 7.2, and sterilize for 15 minutes at 121°C.

<4> Green pus bacilli test method

<a> Presumptive test: Tightly adhere the samples on an mPA-B agar medium in such a way that no air is included, and cultivate for 48 +/-3 hours at 41.5 +/-0.5°C. Those samples on which dark-brown or dark-green colonies have grown are considered positive for the presumptive test.

<b> Confirmation test: Swab the dark-brown to dark-green colonies, transfer to a cetrimide agar medium, and culture until independent colonies develop. After cultivating for 48 +/-3 hours at 35.0 +/-1.0°C, swab the greenish or reddish-brown colonies, and transplant them to a regular agar slant. After cultivating the colonies for 24 +/-2 hours at 41.5 +/-0.5°C, observe whether the bacilli have grown, and if they have, conduct an oxidase test. If a positive result is yielded in the oxidase test, perform a Gram stain procedure, and examine under a microscope. If the bacilli are Gram-negative nonspore-forming bacilli, the sample is considered positive (green pus bacilli-positive) for the confirmation test.

mPA-B agar medium: Heat and dissolve 5 g of L-lysine, 5 g of sodium chloride, 2 g of yeast extract, 5 g of sodium thiosulfate, 1.5 g of magnesium sulfate, 1.25 g of sucrose, 1.25 g of xylose, 1.25 g of lactose, 15 g of agar, 0.08 g of phenol red and 0.8 g of ferric ammonium citrate in 1,000 ml of purified water, and after sterilization, adjust the pH to 7.0 to 7.2. Sterilize for 10 minutes at 115°C, and cool until the temperature drops to between 50 and 60°C. To this add 176.0 mg of sulfapyridine, 8.5 mg of kanamycin sulfate, 37.0 mg of nalidixic acid and 150.0 mg of actidione.

<5> Bacterial count (viable cell count) determination method

Tightly adhere the samples on a standard agar medium in such a way that no air is included, cultivate for 24 +/-2 hours at 35.0 +/-1.0°C, and divide the number of colonies developed by 100 to obtain the bacterial count per 1 ml.

- iv) Except for precipitation, filtering, aeration, addition of carbon dioxide or deaeration, nothing should be done to the water used as the raw material.
- v) The facilities and equipment used for the processes from water sampling to filling the containers must be kept clean and hygienic so that the water used as the raw material will have no chance of becoming contaminated.
- vi) The work from water sampling to filling the containers must be done cleanly and hygienically.
- vii) The bacterial count per 1 ml of product immediately after the containers have been

filled may be no more than 20. The following method shall be used to determine the bacterial count (viable cell count).

<1> Collecting the test specimens and preparing the samples

Collect test specimens directly from the containers. Use cotton dipped in alcohol to wipe around the test areas before opening. Use a sterilized instrument to unseal the containers, open them or open the cans, and after pouring 100 ml of the liquid into the funnel of a membrane filter unit, proceed with suction filtration. Wash the inside of the funnel two or three times using 20 to 30 ml of sterilized purified water, and again proceed with suction filtration. After filtration, use sterilized tweezers to peel the membrane filter from the filter holder, and use this as the sample.

<2> Bacterial count (viable cell count) determination method

Determine this count using the bacterial count (viable cell count) determination method set forth in iii)-<5>.

- d. Records of the sterilization temperatures and sterilization times applicable to the sterilization processes described in c. or records relating to disinfection, and records relating to iii) and vii) in c. must be kept for six months.**

(3) Frozen fruit juice beverages

- a. The fruits used as raw materials for frozen fruit juice beverages must be wholesome and free from bruises, rottenness, blight, etc.**
- b. They must be immersed in water, detergent, etc. to cause any foreign matter on their peels or skins to swell, then washed by brushing or another suitable method, and thoroughly rinsed. They must then be sterilized using a sodium chloride solution or another suitable bactericide, and thoroughly rinsed with water.**
- c. The sterilized fruits must be handled hygienically to ensure that they will not become contaminated.**
- d. Squeezed juices and squeezed fruit juices must be processed hygienically.**
- e. The instruments to be used for production and the containers must be washed using an appropriate method and also sterilized. However, this shall not apply to unused container packages that have been previously sterilized or produced in a way that imparts a sterilizing effect and that have been handled in a way that precludes contamination before use.**
- f. The following method must be used to sterilize or disinfect the squeezed fruit juices (with the exception of fruit juices that have been obtained using a hermetic, fully automatic squeezing machine).**

- i) In sterilizing fruit juices with a pH below 4.0, the center must be heated for 10 minutes at 65°C or a method that achieves an equivalent or better sterilization effect must be used.
  - ii) In sterilizing fruit juices with a pH of 4.0 or above, the center must be heated for 30 minutes at 85°C or a method that achieves an equivalent or better sterilization effect must be used.
  - iii) The fruit juices must be sterilized using a method effective enough to destroy any microorganisms in the raw materials, etc. or in the foods concerned and that might possibly grow.
- g. Records of the sterilization temperatures and sterilization times applicable to the sterilization processes described in f. and records relating to the disinfection also described in f. must be kept for six months.**
- h. Squeezed fruit juices must be added to containers automatically, and the packages must be sealed.**
- i. No additives (with the exception of oxidation inhibitors) that are chemical compounds may be used.**

(4) Fruit juices used as raw materials

- a. The fruits used in the production of the fruit juices must be fresh and other aspects of quality must be excellent. They must be thoroughly washed if necessary.**
- b. Squeezed juices and squeezed fruit juices must be processed hygienically.**

### **3. Storage Standards for Soft Drink Beverages**

- (1) Soft drink beverages contained in glass bottles with caps made of paper must be stored at temperatures below 10°C.
- (2) Those soft drink beverages other than mineral waters, frozen fruit beverages and fruit juices used as raw materials that have a pH of 4.6 or above and a water activity exceeding 0.94 and that have not been sterilized by a method effective enough to destroy the microorganisms which originate in the raw materials, etc. and are present in the foods concerned and which may possibly grow must be stored at temperatures below 10°C.
- (3) Frozen fruit beverages and frozen fruit juices used as raw materials must be stored at temperatures below -15°C.

- (4) Fruit juices used as raw materials must be contained and stored in clean and hygienic container packages.

**4. Standards for soft drink beverages that are prepared and sold by the cup by automatic vending machines and equipment (hereafter defined as the fully automatic soft drink beverage preparation equipment) that automatically prepares the soft drink beverages using liquid raw materials in containers**

- (1) The liquid raw materials from which the soft drink beverages are prepared must comply with the standards specified under Paragraph 1: Standards for Soft Drink Beverage Components; the powdered drink beverages or sugar used in the preparation of the soft drink beverages must comply with the standard specified under Part I: Foodstuffs, Section C: Specific Food Items, Sub-section C2: Powdered Drink Beverages, Paragraph 1: Standards for Powdered Drink Beverage Components; and the crushed ice also used in their preparation must comply with the standards specified under Part I: Foodstuffs, Section C: Specific Food Items, Sub-section C3: Crushed Ice, Paragraph 1: Standards for Crushed Ice Components. Furthermore, the water used in their preparation must be potable.
- (2) Before preparation, undiluted soft drink solution must be placed in transport equipment or containers that have been cleaned and sterilized using a suitable method; after the transport equipment or containers have been automatically filled, they must be securely stoppered or sealed, or similarly treated. However, this does not apply to undiluted soft drink solution that has already been sealed in unused transport equipment or containers that have been handled in such a way that precludes contamination before use.
- (3) The mixing, extraction, dissolution and diluting of undiluted soft drink solution and other solutions must be performed inside automatic cup vending machines or other fully automatic soft drink beverage preparation machines. However, this does not apply to fully automatic soft drink beverage preparation machines constructed to mix the solution externally.
- (4) The undiluted soft drink solution, water and other solutions used to prepare soft drinks through dissolution, extraction, dilution or mixing (hereafter defined as the liquids inside the apparatus) must be maintained at temperatures below 10°C or above 63°C inside automatic cup vending machines or fully automatic soft drink beverage preparation machines. However, this does not apply to soft drink beverages in transport equipment or containers that have been completely stoppered or sealed or subjected to similar treatment.

## **D-2 Powdered Drink Beverages**

### **1. Standards for Powdered Drink Beverage Components**

- (1) The water in that the powdered drink beverage is to be dissolved for drinking must comply with Part I: Foodstuff, Section C: Specific Food Item, Sub-section C1: Soft Drink Beverage, Paragraph 1: Standards for Soft Drink Beverage Components, Sub-paragraphs (1) and (2).
- (2) Arsenic, lead or cadmium must not be present in detectable amounts. The tin content must not exceed 150.0 ppm.

The following method is used to test for arsenic, lead, cadmium and tin.

#### **a. Preparation of sample solution**

Use the wet degradation method described in i) below or the dry incineration method described in ii) below to prepare the sample solution. When testing for arsenic, however, use only the wet degradation method.

##### **i) Wet degradation method**

Prepare a 100 g test sample (for a drink beverage that is diluted for drinking, use an amount equal to that obtained by dividing 100 g by the multiple by that the beverage is to be diluted), transfer it to a decomposition flask, add 30 ml of water to dissolve, then add 20 ml of nitric acid and 10 ml of sulfuric acid. While heating the solution, add nitric acid, 1 to 2 ml at a time, until the solution turns essentially colorless or light yellow. Cool the solution; once it has cooled, add 10 ml of water and 10 ml of ammonium oxalate solution, and heat until a white smoke appears around the neck of the flask. After cooling, add water to total 50 ml, and use this as the sample solution. Using water instead of the test sample, prepare a blank sample solution following the same steps.

##### **ii) Dry incineration method**

Take a 50 g test specimen (for a drink beverage that is diluted for drinking, use an amount equal to that obtained by dividing 50 g by the multiple by that the beverage is to be diluted) and heat it at 450 to 500°C until a nearly white ash is obtained. After cooling, gently add 5 ml of hydrochloric acid (1 → 2) and dissolve the ash-like material. Heat on a water bath until the liquid evaporates. After cooling, dissolve the specimen in enough 1 mol/l hydrochloric acid to make 25 ml of solution, and use this as the sample solution. Using water instead of the test specimen, prepare a blank sample solution following the same steps.

#### **b. Test methods for arsenic, lead, cadmium and tin**

The test method for arsenic is based that in Part I: Foodstuffs, Section C: Specific Food Items, Sub-section C1: Soft Drink Beverages, Paragraph 1: Standards for Soft Drink Beverage Components, Sub-paragraph (3)-b: Test methods for arsenic; the test methods for lead and

cadmium are based on those in Sub-paragraph (3)-c: Test methods for lead and cadmium; and the test method for tin is based on that in Sub-paragraph (3)-d: Test methods for tin.

(3) For powdered drink beverages to that no lactic acid bacteria are added, tests for coliform bacilli must be negative, and the bacterial count must be no more than 3,000 per 1 g of the test specimen. The following coliform bacilli test method and bacterial count (viable cell count) determination method must be used.

**a. Collecting the test specimens and preparing the samples**

Wipe the surfaces of the containers with cotton soaked with alcohol; use a sterilized implement to unseal the containers; place 10 g of the contents into an aseptically sterilized test jar; add a sterile phosphate buffer solution to total 100 ml; put the stopper in place (if the solution is carbonated, mix to release the carbon dioxide and then put the stopper in place); shake well, and use this as the test solution.

**b. Coliform bacilli test method**

Prepare samples from 10 ml and 1 ml of the stock solution as well as 1 ml each of a 10x diluted solution, and use these samples to test for coliform bacilli in accordance with the method under Part I: Foodstuffs, Section B: General Food Storage Standards, Paragraph 1, Sub-paragraph (2): Coliform Bacilli Test Method.

**c. Bacterial count (viable cell count) determination method**

Using the sample solution as well as 10x, 100x and 1,000x diluted solutions as test specimens, determine the bacterial count in accordance with Part I: Foodstuffs, Section C: Specific Food Items, Sub-section C3: Crushed Ice, Paragraph 1: Standards for Crushed Ice Components, Sub-paragraph 2-b: Bacterial Count (viable cell count) Determination Method.

(4) For powdered drink beverages to which lactic acid bacteria have been added, tests for coliform bacilli must be negative, and the bacterial count (excluding the lactic acid bacteria count) must be no more than 3,000 per 1 g of the test specimen.

The following methods shall be used to test for the coliform bacilli and determine the bacterial count to this end.

**a. Collecting test specimens and preparing the samples**

Follow the same procedure as in a. Collecting the test specimens and preparing the samples in (3).

**b. Coliform bacilli test method**

Test for coliform bacilli using the method described above in b. Coliform bacilli test method in (3).

**c. Bacterial count (viable cell count; excluding lactic acid bacteria) determination method**

- i) Provide at least two sterilized petri dishes each for the sample solution as well as 10x, 100x and 1,000x diluted solutions; place exactly 1 ml of each sample solution in the petri dishes using a sterilized pipette; heat and dissolve; add about 15 ml of glucose added agar medium with 1.0 µg/ml penicillin G1 potassium added that has been kept at a temperature of 43 to 45°C; gently swirl the petri dishes to mix; allow to cool and solidify. Do not allow more than 20 minutes to elapse after placing the sample solutions in the petri dishes before adding the agar medium.

Once the medium has solidified, place the samples upside down inside an incubator.

Samples prepared by mixing 1 ml of diluted solution to that no sample solution was added with the medium are used as a control to verify that the petri dishes, dilution solutions and medium were in fact sterilized and handled perfectly. In addition, prepare samples by mixing the sample solution with a glucose added agar medium to that no penicillin G1 potassium was added as a control, and use them to verify that the lactic acid bacteria have been completely eliminated by the 1.0 µg/ml penicillin G1 potassium.

The petri dishes must have a diameter of 9 to 10 cm and a depth of 1.5 cm.

The cultivation temperature must be set to 35°C (a 1°C margin either way is acceptable), and the cultivation time must be set to 24 hours (a 2-hour margin way is acceptable).

Glucose-added agar medium with penicillin G1 potassium added: Dissolve 5 to 10 g of glucose in a small amount of water; to this add a 2.5 to 3% nutrient agar medium that has been heated and dissolved; mix; divide the medium and sterilize it for 15 minutes at 121°C. The penicillin G1 potassium must be added to the medium and mixed immediately prior to the preparation of the petri dish.

- ii) Provide at least two sterilized petri dishes each for the sample solution as well as 10x, 100x and 1,000x diluted solutions; place exactly 1 ml of each sample solution in the petri dishes using a sterilized pipette; heat and dissolve; add about 15 ml of a plate count agar medium with added B.C.P. containing 4% sodium chloride that has been kept at a temperature of 43 to 45°C, gently swirl the petri dishes to mix; allow to cool and solidify. Do not allow more than 20 minutes to elapse after placing the sample solutions in the petri dishes before adding the agar medium.

Once the medium has solidified, place the samples upside down, and cultivate for 24 hours (a 2-hour margin either way is acceptable) at 35°C (a 1°C margin either way is acceptable).

Prepare samples by mixing 1 ml of a diluted solution to that no sample solution was added with the medium to serve as a control, and verify that the petri dishes,

dilution solutions and medium were in fact sterilized and handled perfectly.

The petri dishes must have a diameter of 9 to 10 cm and a depth of 1.5 cm.

Plate count agar medium with added B.C.P. containing 4% sodium chloride: Add 2.5 g of yeast extract, 5 g of peptone, 1 g of glucose, 40 g of sodium chloride and 15 g of powdered agar to 1,000 ml of water; heat and dissolve; adjust the pH to between 6.8 and 7.0; add the B.C.P. in a 0.004 to 0.006% proportion and sterilize for 15 minutes at 121°C.

- iii) The number obtained by adding the bacterial count determined in the cultivation of i) to the bacterial count determined in the cultivation of ii) serves as the bacterial count.

The method used to determine the bacterial count is based on c. Bacterial count (viable cell count) determination method in (3).

## **2. Production Standards for Powdered Drink Beverages**

Powdered drink beverages must be kept in containers such as glass bottles or metal or composite resin containers (including containers made of paper or cellophane laminated with composite resin) that have been washed and dried using the appropriate methods, or they must be stored in metal or composite resin transport equipment that can be stoppered or sealed and can also be protected from dust, moisture and insects. However, containers that have been manufactured by a production method having the same effect as washing and those that have been handled in a manner preventing them from becoming contaminated before use need not be washed.

## **3. Storage Standards for Powdered Drink Beverages Stored in Automatic Cup Vending Machines**

Powdered drink beverages that are stored in automatic cup vending machines must be stored after the action specified in 2 Production Standards for Powdered Drink Beverages has been taken.

## **D-3 Crushed Ice**

### **1. Standards for Crushed Ice Components**

- (1) Crushed ice must test negative for coliform bacilli, and the bacterial count in 1 ml of melted ice may be no more than 100.

(2) The coliform bacilli test for crushed ice is performed under Part I: Foodstuffs, Section B: General Food Storage Standards, Paragraph 1, Sub-paragraph (2): Coliform Bacilli Test Method, and the bacterial count is determined as described below.

**a. Collecting the test specimens and preparing the samples**

Wash the test specimens thoroughly in sterilized distilled water; pour them into sterilized containers; shake the crushed ice at room temperature or in warm water at a temperature below 40°C to ensure that the ice is completely melted. Immediately prepare a sample solution, as well as 10x, 100x and 1,000x diluted solutions using the melted ice.

**b. Bacterial count (viable cell count) determination method**

Provide at least two sterilized petri dishes each for the sample solution as well as the 10x, 100x and 1,000x diluted solutions to be used for the count; place exactly 1 ml of each sample solution in each petri dish using a sterilized pipette; heat and dissolve; add about 15 ml of standard agar medium that has been kept at a temperature of 43 to 45°C; gently swirl the petri dishes to mix; allow to cool and solidify. Do not allow more than 20 minutes to elapse after placing the sample solutions in the petri dishes before adding the agar medium.

Once the medium has solidified, place the samples upside down inside an incubator.

Prepare samples by mixing 1 ml of a diluted solution to that no sample solution was added with the medium to serve as a control, and verify that the petri dishes, dilution solutions and medium were in fact sterilized and handled perfectly.

The petri dishes must have a diameter of 9 to 10 cm and a depth of 1.5 cm.

Standard agar medium: Add 5.0 g of peptone, 2.5 g of yeast extract, 1.0 g of glucose, and 15.0 g of agar to 1,000 ml of purified water; heat and dissolve; sterilize under high pressure. The final pH must be between 7.0 and 7.2.

The cultivation temperature must be set to 35°C (a 1°C margin either way is acceptable), and the cultivation time must be set to 24 hours (a 2-hour margin either way is acceptable). Remove the petri dishes from the incubators and calculate the number of bacterial colonies that have grown on the medium, using a magnifying glass with low magnification (1.5x) under artificial light, if possible. If the colonies cannot be calculated immediately after the cultivation time has elapsed, the sample may still be used to obtain this figure within 24 hours provided that the dishes are stored in a refrigerator at a temperature of 5°C.

The bacterial count is calculated as follows.

**i) When there are 30 to 300 colonies on one plate**

Take plates on that 30 to 300 colonies have grown among the plates containing the solutions and diluted solutions to be examined, and determine the bacterial count.

**ii) When there are more than 300 colonies on all the plates**

If the number of colonies exceeds 300 for all the diluted solutions examined, determine the bacterial count using the mass colony plate counting method described below for the most diluted solution.

**iii) When there are fewer than 30 colonies on all the plates**

If there are fewer than 30 colonies on all the plates, determine the bacterial count for the least diluted solution. If this is the case, however, "not more than" must be added to the number determined.

**iv) When the colonies are scattered**

If there are scattered colonies on the selected plate, determine the bacterial count for those colonies that meet the following conditions:

<1> When the other colonies are well dispersed so that the presence of scattered colonies will not interfere with determining the bacterial count

<2> When the scattered colonies cover less than one-half of the plate)

**v) Laboratory accidents (LA)**

The following types of special events are defined as laboratory accidents (LA).

<1> When no colonies have developed

<2> When the scattered colonies cover more than one-half of the plate

<3> When there is clear evidence of contamination

<4> When anything else is considered inappropriate

**vi) Calculation method**

The bacterial count is obtained by multiplying the mean number of colonies on two or more usable plates by the dilution strength. The two higher digits of the figure obtained are used as the significant number for an approximate calculation.

**vii) Mass colony plate counting method**

If the number of colonies on one plate marginally exceeds 300, count the number of colonies on one part of the plate as follows using a calculating board precisely partitioned into 1 cm<sup>2</sup> sections. Use this count to calculate the number of colonies on the entire plate.

<1> If the number of colonies in 1 cm<sup>2</sup> is 10 or fewer, create two diameters passing through the center of the colony calculating board and at right angles to each other, divide the board into sections of 1 cm from the center, count the number of colonies in an area covering six sections, calculate the average number of

colonies per 1 cm<sup>2</sup>, and multiply this by the total surface area of the plate to determine the bacterial count.

<2> If the number of colonies in 1 cm<sup>2</sup> exceeds 10, count the number in an area covering four sections, and determine the bacterial count in the same way as for i) above.

## **2. Production Standards for Crushed Ice**

The water used as the raw material for producing the crushed ice must be potable water.

## **D-4 Frozen Confections**

### **1. Standards for Frozen Confection Components**

- (1) Frozen confections must have a bacterial count (for frozen confections using fermented milk or lactic acid bacteria beverages as a raw material, the number of bacteria excluding lactic acid bacteria and yeast) of less than 10,000 per 1 ml of melted confection.
- (2) Frozen confections must test negative for coliform bacilli.
- (3) The following methods are used to test for the coliform bacilli in frozen confections and to determine the bacterial count.

#### **a. Collecting the test specimens and preparing the samples**

As judgment will be made as to whether component parts meet the relevant standards, samples must be taken using sterilized implements, aseptically placed into sterilized sampling bottles, and used within four hours. Until use, the samples should be kept or transferred at as constant a temperature as possible.

Prepare the samples as follows. First, melt the test specimens in as short a period of time as possible at 40°C or below, and pour 10 ml into bottles with ground stoppers. To samples whose bacterial count (total viable cell count) is to be determined, add 90 ml of sterilized physiological saline solution to dilute the sample solution 10x. Further dilute in stages using sterilized physiological saline solution until 30 to 300 colonies can be cultured on a plate. To samples that are to be tested for coliform bacilli, add 90 ml of sterilized physiological saline solution to dilute the sample solution 10x.

#### **b. Bacterial count (viable cell count) determination method**

Provide at least two sterilized petri dishes for each sample; use a sterilized pipette to transfer 1 ml of a sample into each petri dish; add approximately 15 ml of standard agar medium (defined as the medium specified in Part I: Foodstuffs, Section C: Specific Food Items,

Sub-section C3: Crushed Ice, Paragraph 1: Standards for Crushed Ice Component, Sub-paragraph 2-b: Bacterial Count (viable cell count) Determination Method) that has been preheated, dissolved and kept at a temperature of 43 to 45°C; gently swirl the petri dishes to mix; allow to cool and solidify. These steps must be completed within 20 minutes of placing the samples in the petri dishes. Once the medium has solidified, place the samples upside down in an incubator, and cultivate at 35°C (a 1°C margin either way is acceptable) for 48 hours (a 3-hour margin either way is acceptable). Prepare control samples by mixing the same amount of the medium as was added to the samples with 1 ml of the sterilized physiological saline solution used to dilute the test specimen; swirl gently and follow the same steps as with the test samples; use them to verify that the petri dishes, sterilized physiological saline solution and medium were in fact sterilized and handled perfectly.

The petri dishes must have a diameter of 9 to 10 cm and a depth of 1.5 cm.

The bacterial count is calculated as follows.

Using a colony calculator under a constant beam of light, determine the number of colonies for a sample with 30 to 300 colonies per plate (if there are no samples with 30 to 300 colonies per plate, use a sample whose scattered colonies cover less than one-half of the plate and whose other colonies are well dispersed so they will not interfere with determining the bacterial count); add the figure obtained by multiplying the dilution strength of the sample concerned by the value obtained by averaging out the number of colonies per plate for each sample with the same dilution strength; the value obtained by dividing the sum obtained by the number of types based on each dilution strength of the valid plates serves as the bacterial count. The following are considered laboratory accidents (LA).

- i) When no colonies have developed
- ii) When the scattered colonies cover more than one-half of the plate
- iii) When there is clear evidence of contamination
- iv) When anything else considered inappropriate

### **c. Coliform bacilli test method**

Prepare at least two sterilized petri dishes, and use a sterilized pipette to transfer 1 ml of the sample to each dish; add approximately 10 to 15 ml of desoxycholate agar medium that has been preheated, dissolved and kept at a temperature of 43 to 45°C; gently swirl to mix; allow to cool and solidify. After the medium has solidified, add 3 to 4 ml of the same medium to the surface and allow to cool and solidify. These steps must be completed within 20 minutes of placing the samples in the petri dishes.

Once the medium has solidified, turn the samples upside down; cultivate them at 35°C (a 1°C margin either way is acceptable) for 20 hours (a 2-hour margin either way is acceptable), and observe whether colonies have developed. Samples in that dark red colonies are discernible

are considered positive for the presumptive test; all other samples shall be considered negative.

If the samples are positive for the presumptive test, swab representative cultures onto an EMB medium; after cultivation at 35°C (a 1°C margin either way is acceptable) for 24 hours (a 2-hour margin either way is acceptable), swab the typical coliform bacillus colonies (if there are no typical colonies, two or more colonies resembling typical colonies), and transplant each to a lactose broth fermentation tube and agar slant (if colonies resembling typical colonies have been swabbed, then transplant each sample that has been swabbed from each colony to a separate tube and agar slant).

Cultivate the bacilli at 35°C (a 1°C margin either way is acceptable) for 48 hours (a 3-hour margin either way is acceptable) when using the lactose broth fermentation tube or at 35°C (a 1°C margin either way is acceptable) for 24 hours when using the agar slant. If gas generation is confirmed in the lactose broth fermentation tube, perform a microscopic test on bacilli cultivated on the corresponding agar slant, and if Gram-negative nonspore-forming bacilli are found, this is considered as coliform bacilli positive.

The petri dishes must have a diameter of 9 to 10 cm and a depth of 1.5 cm.

Desoxycholate agar medium: Heat and dissolve 10 g of peptone, 15 to 25 g of agar, 10 g of lactose, 5 g of common salt, 2 g of ferric ammonium citrate and 2 g of monopotassium phosphate in 1,000 ml of water; adjust the pH of the filtrate obtained after filtering the solution to between pH 7.3 and 7.5; add 1g of sodium desoxycholate and 33 mg of neutral red, and readjust the pH to 7.3 to 7.5.

- (1) The water used as the raw material for producing the frozen confections must be potable water.
- (2) The raw materials of the frozen confections (excluding fermented milk or lactic acid bacteria beverages) must be heated and sterilized at 68°C for 30 minutes or sterilized using a method that achieves an equivalent or better sterilization effect.
- (3) When removing frozen confections from freezing tubes, the water used to heat the outsides of the tubes must be potable running water.
- (4) When packing the frozen confections into containers, a packing machine must be used; and when capping the packages, a capping machine must be used.
- (5) Melted water from frozen confections may not be used as a raw material in frozen confections. However, this does not apply to water that has been heated and sterilized as in (2) above.
- (6) The frozen confection vessels and containers must be washed and sterilized using appropriate methods prior to use. However, this does not apply to already washed and

sterilized containers or to containers that have been produced in such a way that imparts a sterilizing effect and have been handled in a manner preventing them from becoming contaminated until use.

- (7) The containers used when storing frozen confections must be sterilized using appropriate methods.
- (8) The raw materials and products must be stored in covered containers, and neither the raw materials nor products may be touched directly while they are being handled.

## **D-5 Meats and Whale Meat (with the exception of frozen whale meat to be eaten raw; hereafter the same in this section)**

### **1. Storage Standards for Meats and Whale Meat**

- (1) Meats and whale meat must be stored at temperatures below 10°C. However, thinly-sliced frozen meats or whale meat that has been placed inside containers must be stored at temperatures below -15°C.
- (2) Meats and whale meat must be placed inside clean and hygienically covered containers or wrapped in clean and hygienic synthetic resin film, synthetic resin coated paper, parchment paper, paraffin paper or cloth for transportation.

### **2. Preparation Standards for Meats and Whale Meat**

Meats and whale meat must be prepared in a hygienic location using clean and hygienic equipment.

## **D-6 Edible Birds' Eggs**

### **1. Standards for Edible Birds' Egg Components**

- (1) Sterilized liquid eggs (defined as the liquid eggs of chickens that have been sterilized; hereafter the same) must test negative for salmonella, using a 25 g test specimen.
- (2) The bacterial count of non-sterilized liquid eggs (defined as the liquid eggs of chickens other than sterilized liquid eggs; hereafter the same) must be under 1,000,000 per gram of test specimen.

## **2. Production Standards for Edible Birds' Eggs (limited to the liquid eggs of chickens)**

### **(1) General standards**

The liquid eggs of chickens must be produced using a method that satisfies the following standards.

- a. The chicken eggs in their shells used for production (defined below as ingredient eggs) may not be eggs that are unfit for eating.**
- b. The ingredient eggs must be handled after having been sorted into regular eggs, soiled-shell eggs, soft shell eggs and broken shell eggs.**

### **(2) Individual standards**

#### **a. Sterilized liquid eggs**

Sterilized liquid eggs must be produced using a method that satisfies the following standards.

- i) The soiled shell eggs, soft shell eggs and broken shell eggs used for production must be shelled, heated and sterilized within 24 hours of arrival (or within 72 hours of being stored at temperatures below 8°C).
- ii) When regular eggs used for production are to be stored for more than 3 days after arrival, they must be stored at temperatures below 8°C, and they must be shelled as soon as possible.
- iii) Soiled shell eggs used for production must be washed and sterilized using a sodium hypochlorite solution of 150 ppm or more, or they must be sterilized using a method that achieves an equivalent or better sterilization effect.
- iv) When ingredient eggs are to be washed, they must be separated from soiled shell eggs, and then washed under potable running water immediately before they are shelled.
- v) The eggs must be shelled and packed in one continuous integrated process.
- vi) Apparatus that is clean and easy to wash and sterilize must be used for breaking the eggs.
- vii) When machinery is to be used to break the eggs, it must not be of the centrifugal separation or pressing/squeezing type.
- viii) The equipment used to break eggs (including the equipment used for filtering when egg shells are to be filtered out) must be cleaned and sterilized periodically, both

upon completion of work and while work is underway.

- ix) If eggs unfit for eating have been shelled by mistake, the liquid eggs of chickens into which said eggs have been mixed must be immediately discarded, and the apparatus used to break the eggs must be washed and sterilized.
- x) The liquid eggs of chickens prior to sterilization must be transferred promptly after breaking to a storage tank with cooling unit and cooled to temperatures below 8°C. However, this does not apply when they are sterilized immediately after breaking.
- xi) When the liquid eggs of chickens prior to sterilization are to be stored for longer than 8 hours, they must be cooled promptly after breaking to temperatures below 5°C.
- xii) The liquid eggs of chickens must be heated and sterilized by one of the following methods or a method that achieves an equivalent or better sterilization effect.

<1> When the liquid eggs of chickens (with the exception of sweetened or salted eggs; hereafter the same for <2>) are to be heated and sterilized using a continuous method, they must be heated and sterilized for at least 3 minutes 30 seconds in accordance with the relevant category Column 1 of the table below and at the temperature given in Column 2 of the same table.

Column 1	Column 2
Whole eggs	60°C
Egg yolks	61°C
Egg whites	56°C

<2> When the liquid eggs of chickens are to be heated and sterilized using a batch method, they must be heated and sterilized for at least 10 minutes in accordance with the category in Column 1 of the table below and at the temperature given in Column 2 of the same table.

Column 1	Column 2
Whole eggs	58°C
Egg yolks	59°C
Egg whites	54°C

<3> When sweetened or salted liquid eggs of chickens are to be heated and sterilized, they must be heated and sterilized using a continuous method for at least 3 minutes 30 seconds in accordance with the category in Column 1 of the table below and at the temperature given in Column 2 of the same table.

Column 1	Column 2
Egg yolks to which 10% of salt has been added	63.5°C
Egg yolks to which 10% of sugar has been added	63.0°C
Egg yolks to which 20% of sugar has been added	65.0°C
Egg yolks to which 30% of sugar has been added	68.0°C
Whole eggs to which 20% sugar has been added	64.0°C

- xiii) After heating and sterilizing, the liquid eggs of chickens must be cooled to a temperature below 8°C.
- xiv) When the liquid eggs of chickens are to be packed into containers after cooling, they must be packed into sterilized containers and sealed immediately using a method that does not allow microbial contamination.

**b. Non-sterilized liquid eggs**

Non-sterilized liquid eggs must be produced using a method that satisfies the following standards.

- i) The soiled shell eggs, soft shell eggs and broken shell eggs used for production must be shelled promptly after arrival.
- ii) When regular eggs used for production are to be stored for more than 3 days after arrival, they must be stored at temperatures below 8°C, and they must be shelled as soon as possible.
- iii) Soiled shell eggs used for production must be washed and sterilized using a sodium hypochlorite solution of 150 ppm or more, or they must be sterilized using a method that achieves an equivalent or better sterilization effect.
- iv) When ingredient eggs are to be washed, they must be separated from soiled shell eggs and then washed under potable running water, immediately before they are shelled.
- v) The equipment used for processes from breaking the eggs to packing them into containers must be cleaned and sterilized periodically before and after work, each time the ingredient eggs of one lot are processed or while work is underway.
- vi) Apparatus that is clean and easy to wash and sterilize must be used for breaking the eggs.
- vii) When machinery is to be used to break the eggs, it must not be of the centrifugal separation or pressing/squeezing type.

- viii) If eggs unfit for eating have been shelled by mistake, the liquid eggs of chickens into which the eggs have been mixed must be immediately discarded, and the apparatus used to break the eggs must be washed and sterilized.
- ix) The temperature must be controlled in such a way that the temperature of the liquid eggs of chickens does not rise beyond the appropriate level at any point in the processes, from breaking the eggs to packing them.
- x) The liquid eggs of chickens must be cooled to temperatures below 8°C promptly after breaking.
- xi) When the liquid eggs of chickens are to be packed into containers after cooling, they must be packed into sterilized containers and sealed immediately using a method that does not allow microbial contamination.

### **3. Storage Standards for Edible Birds' Eggs (limited to the liquid eggs of chickens)**

- (1) The liquid eggs of chickens must be stored at temperatures below 8°C (or below -15°C when the liquid eggs of chickens are frozen).
- (2) The equipment used to transport the products must be washed, sterilized and dried.
- (3) The tanks used to transport the products must be made of stainless steel, and they must be washed by a stationary washing unit and sterilized or washed and sterilized using a method that achieves an equivalent or better effect.

### **4. Usage Standards for Edible Birds' Eggs (limited to the eggs of chickens in their shells)**

When supplying chicken eggs in their shells for eating or drinking without heating and sterilizing them, regular eggs for eating raw whose best-before date has not passed must be used.

## **D-7 Blood, Blood Corpuscles and Blood Plasma**

### **1. Processing Standards for Blood Corpuscles and Blood Plasma**

- (1) The blood used for processing (defined as blood used as the raw material; hereafter the same) must be cooled to temperatures below 4°C immediately after collecting, and after cooling, it must be kept at temperatures below 4°C.

- (2) The blood used as the raw material must be very fresh, and its properties and condition must be normal.
- (3) The apparatus used for processing the blood must be washed and sterilized by the appropriate method.
- (4) The processing must be continuous and integrated.
- (5) Except for cases where it is heated and sterilized, the processing must be undertaken without the temperature of the blood corpuscles or blood plasma exceeding 10°C.
- (6) In the case of the freezing, this must be done in such a way that the temperature of the blood corpuscles or blood plasma will drop below -18°C promptly after separation.

## **2. Storage Standards for Blood, Blood Corpuscles and Blood Plasma**

- (1) Blood, blood corpuscles and blood plasma must be stored at temperatures below 4°C.
- (2) Frozen blood, blood corpuscles and blood plasma must be stored at temperatures below -18°C.
- (3) Blood, blood corpuscles and blood plasma must be packed and stored in clean and hygienic containers.

## **D-8 Meat Products**

### **1. Standards for Meat Product Components**

#### (1) General standards

Meat products may not contain nitrite radicals in any amount exceeding 0.070 g per 1 kg.

#### (2) Individual standards

**a. Dried meat products (defined as meat products that have been dried and are sold as dried meat products; hereafter the same) must comply with the following standards.**

- i) The meat products must test negative for E. coli (defined as the kind of coliform bacilli that generate acids and gases after breaking down lactose when the bacilli has been cultivated for 24 hours at 44.5°C; hereafter the same).
- ii) The water activity must be under 0.87.

**b. Unheated meat products (defined as meat products that is not heated and sterilized by a method in which the meat is, after pickled in salt, smoked, dried and heated for 30 minutes at a temperature of 63°C measured at the center, or a method that achieves an equivalent or better sterilizing effect, and that are sold as unheated meat products; however, dried meat products are excluded; hereafter the same) must comply with the following standards.**

- i) The E. coli count may be no more than 100 per 1 g of the test specimen.
- ii) The staphylococcus aureus count may be no more than 1,000 per 1 g of the test specimen.
- iii) The products must test negative for salmonella (defined as Gram-negative nonspore-forming bacilli and facultative anaerobic bacteria with motility that test negative for acetoin, positive for lysine, positive for hydrogen sulfide and negative for ONPG, and that break down glucose but not lactose or saccharose; hereafter the same).

**c. Special heated meat products (defined as meat products that have been heated and sterilized using a method that heats the meat for 30 minutes at a temperature of 63°C at the center or a method that achieves an equivalent or better effect; however, dried meat products and unheated meat products are excluded; hereafter the same) must comply with the following standards.**

- i) The E. coli count may be no more than 100 per 1 g of the test specimen.
- ii) The clostridial bacteria (defined as Gram-positive spore-forming bacilli and anaerobic bacteria that reduces sulfurous acid; hereafter the same) count may be no more than 1,000 per 1 g of the test specimen.
- iii) The staphylococcus aureus count may be no more than 1,000 per 1 g of the test specimen.
- iv) The products must test negative for salmonella.

**d. Those products among heated meat products (defined as meat products other than dried meat products, unheated meat products and special heated meat products; hereafter the same) that have been heated and sterilized after being packed into containers must comply with the following standards.**

- i) The products must test negative for coliform bacilli.
- ii) The clostridial bacteria count may be no more than 1,000 per 1 g of the test specimen.

**e. Those meat products among heated meat products that have been packed into containers after being heated and sterilized must comply with the following standards.**

- i) The products must test negative for E. coli.
- ii) The clostridial bacteria count may be no more than 1,000 per 1 g of the test specimen.
- iii) The products must test negative for salmonella.

## **2. Production Standards for Meat Products**

### **(1) General standards**

Meat products must be produced using a method that complies with the following standards.

- a. The meat used as the raw material for production must be satisfactorily fresh and have minimal microbial contamination.**
- b. Frozen meat used as the raw material for the production of meat products must be thawed out in a hygienic location. When water is used to thaw it out, potable running water must be used.**
- c. The meat must be stored in clean and easy-to-wash impermeable containers made of metal, synthetic resin, etc.**
- d. The number of spores per 1 g of spices, sugar and starch used for production of the meat products may be no more than 1,000.**
- e. Clean apparatus that is easy to wash and sterilize must be used for production.**

### **(2) Individual standards**

#### **a. Dried meat products**

Dried meat products must be produced using a method that complies with the following standards.

- i) When smoking or drying meat, the temperature of the meat products must be kept at less than 20°C or more than 50°C, or the products must be kept under conditions that inhibit the growth of microorganisms to comparable or better levels, and it must be smoked or dried until the water activity is reduced to under 0.87.

When smoking or drying products while keeping their temperature at more than 50°C, the time during which the product temperature is above 20°C and below 50°C

must be kept to a minimum.

- ii) After smoking or drying, the products must be handled hygienically.

#### **b. Unheated meat products**

Unheated meat products must be produced using a method that complies with any of the following standards.

- i) When the meat used as the raw material consists solely of lumps of meat (defined as lumps of meat only; no internal organs; hereafter the same)

<1> The meat used as the raw material for production must be cooled to under 4°C within 24 hours after slaughter and stored at under 4°C after cooling, and its pH must be less than 6.0.

<2> The frozen meat used as the raw material for production must be thawed out in such a way that its temperature does not rise above 10°C.

<3> The trimming of the meat used as the raw material for production must be performed in such a way that its temperature does not rise above 10°C during the process.

<4> When pickling the meat products in salt using sodium nitrite, one of the following methods must be used.

<a> The meat in lump form must be pickled in salt using the dry curing method, saline solution method or manual injection method using a single needle (hereafter referred to as the single needle injection method) until the water activity is reduced to under 0.97 while keeping its temperature at less than 5°C. However, the specification for the water activity does not apply to end products whose water activity is to be more than 0.95.

When the dry curing method is used, the meat must be pickled in common salt, potassium chloride or a combination thereof that exceeds 6% of the weight of the meat, and more than 200 ppm of sodium nitrite; when the saline solution method or single needle injection method is used, it must be pickled in common salt, potassium chloride or a combination thereof that exceeds 15% of the weight of the meat, and more than 200 ppm of sodium nitrite.

When the saline solution method is used, the meat must be sufficiently immersed in the salting solution.

<b> To remove the salt from salted meat, potable water with a temperature under 5°C must be used, and the water must be changed during the removal.

<c> Smoking or drying of the meat must be done in lump form until the water activity is reduced to under 0.95 while keeping its temperature at less than 20°C or more than 50°C. However, the specification for the water activity does not apply to end products whose water activity is to be more than 0.95.

Furthermore, when smoking or drying meat while keeping its temperature at higher than 50°C, the time during which the product temperature is above 20°C and below 50°C must be kept to the minimum.

<5> When meat is to be pickled in salt without the use of sodium nitrite, the following method must be used.

<a> The meat must be pickled in salt while in lump form using the dry curing method while keeping its temperature at less than 5°C by applying an adequate amount of common salt, potassium chloride or a combination thereof that exceeds 6% of the weight of the meat to all parts excluding the surface fat areas for at least 40 days.

<b> To wash the surfaces of meat pickled in salt, chilled potable water must be used, and the water must be changed during washing.

<c> Smoking or drying of the meat must be done in lump form while keeping its temperature at less than 20°C for at least 53 days until the water activity is reduced to under 0.95.

<6> After smoking or drying, the products must be handled hygienically.

ii) When the meat used as the raw material is other than that consisting solely of lumps of meat

<1> The frozen meat used as the raw material for production must be thawed out in such a way that its temperature does not rise above 10°C.

<2> The trimming of the meat used as the raw material for production must be performed in such a way that its temperature does not rise above 10°C.

<3> The meat used as the raw material for production must be cut in such a way that the diameter at its widest is less than 20 mm.

<4> The meat must be pickled in salt using common salt, potassium chloride or a combination of the two that exceeds 3.3% of the weight of the meat (excluding the bones and fat), and more than 200 ppm of sodium nitrite.

<5> To remove salt from salted meat, potable water at a temperature under 5°C

must be used, and the water must be changed during the removal.

<6> Smoking or drying of the meat must be done for at least 20 days while keeping the product temperature at less than 20°C, until the pH is under 5.0 and the water activity is reduced to under 0.91 (or a pH of under 5.4 and a water activity of under 0.91 when smoking or drying meat at a product temperature exceeding 15°C) or until the pH is under 5.3 and the water activity is reduced to under 0.96. However, meat stored at room temperature must be smoked or dried until the pH is under 4.6, or the pH is under 5.1 and the water activity is reduced to under 0.93.

<7> In the cases described in <a> through <c> below, the use of common salt, potassium chloride or a combination thereof in <4> and the smoking or drying period in <6> do not apply.

<a> When producing meat products consisting of meat as the raw material that has been frozen at the center as specified in Column 1 of the following table for the period specified in Column 3 in accordance with the temperatures specified in Column 2 or that has been frozen using a method that achieves an equivalent or better effect

<b>Column 1</b>	<b>Column 2</b>	<b>Column 3</b>
Meat that is less than 150 mm thick	Temperatures less than -29°C	6 days
	Temperatures above -29°C but less than -24°C	10 days
	Temperatures above -24°C but less than -15°C	20 days
Meat that is more than 150 mm but less than 675 mm thick	Temperatures less than -29°C	12 days
	Temperatures above -29°C but less than -24°C	20 days
	Temperatures above -24°C but less than -15°C	30 days

<b> When producing meat products consisting of meat as the raw material that has been heated at the center for the time specified in Column 2 in accordance with the temperatures specified in Column 1 or that has been heated using a method that achieves an equivalent or better effect (applicable only when the time during which the meat temperature exceeds 20°C and is below 50°C is less than 120 minutes)

Column 1	Column 2
50°C	580 minutes
51°C	300 minutes
52°C	155 minutes
53°C	79 minutes
54°C	41 minutes
55°C	21 minutes
56°C	11 minutes
57°C	6 minutes
58°C	3 minutes
59°C	2 minutes
60°C	1 minute
63°C	One instant

<c> When producing meat products in such a way that their water activity is reduced to under 0.91

<8> After smoking or drying, the products must be handled hygienically.

### c. Special heated meat products

Special heated meat products must be produced using a method that complies with the following standards.

- i) The meat used as the raw material for production must be cooled to below 4°C within 24 hours after slaughter and stored in lumps at below 4°C after cooling, and its pH must be less than 6.0.
- ii) The frozen meat used as the raw material for production must be thawed in such a way that its temperature does not rise above 10°C.
- iii) The trimming of the meat used as the raw material for production must be performed in such a way that its temperature does not rise above 10°C.
- iv) When meat is to be pickled in salt, it must be done in lump form using the dry curing method or saline solution method.
- v) To remove salt from salted meat, potable water at a temperature below 5°C must be used, and the water must be changed during the removal.
- vi) When seasonings, etc. are to be used in production, they must be applied only to the surfaces of the meat.
- vii) The meat must be sterilized in lump form by heating for the period specified in

Column 2 of the following table in accordance with the temperatures specified in Column 1 as measured at the center or using a method that achieves an equivalent or better effect. For this process, the time during which the product temperature exceeds 35°C and is below 52°C must be less than 170 minutes.

Column 1	Column 2
55°C	97 minutes
56°C	64 minutes
57°C	43 minutes
58°C	28 minutes
59°C	19 minutes
60°C	12 minutes
61°C	9 minutes
62°C	6 minutes
63°C	Split-second

- viii) After heating and sterilizing, the products must be sufficiently cooled in a hygienic location. In this process, the time during which the product temperature exceeds 25°C and is below 55°C must be less than 200 minutes. When using water for cooling, potable running water must be used.
- ix) After cooling, the products must be handled hygienically.

**d. Heated meat products**

Heated meat products must be produced using a method that complies with the following standards.

- i) The products must be sterilized using a method that heats them for 30 minutes at a temperature of 63°C as measured at the center or a method that achieves an equivalent or better effect (for products containing fish that are sterilized after having been packed in air-tight containers, a method that heats them for 20 minutes at a temperature of 80°C as measured at the center or a method that achieves an equivalent or better effect).
- ii) After heating and sterilizing, the products must be sufficiently cooled in a hygienic location. When using water, potable running water must be used.
- iii) Products that have been packed in containers after heating and sterilizing must be handled hygienically after being cooled.

**e. When meat products are to be produced after pickling in salt, smoking, drying or sterilizing using a method other than one that is specified in a., b., c. or d. of (2) in this item or when meat products that have been pickled in salt, smoked, dried or sterilized using a method**

other than one that is specified in a., b., c. or d. of (2) in this item are to be imported, permission must be obtained from the Ministry of Health, Labor and Welfare.

### **3. Storage Standards for Meat Products**

#### (1) General standards

**a. Frozen meat products (defined as meat products that are to be sold as frozen meat products) must be stored at temperatures below -15°C.**

**b. The products must be placed inside clean and hygienic containers and sealed or capped, or they must be wrapped in clean and hygienic synthetic resin film, synthetic resin-coated paper, parchment paper or paraffin paper for transportation.**

#### (2) Individual standards

##### **a. Unheated meat products**

Unheated meat products must be stored at temperatures below 10°C (or below 4°C for products in which the meat used as the raw material consists solely of lumps of meat and whose water activity is more than 0.95). However, this does not apply to products in which the meat used as the raw material is other than that consisting solely of lumps of meat that have a pH of under 4.6 or a pH of under 5.1 and a water activity less than 0.93.

##### **b. Special heated meat products**

Special heated meat products with a water activity of more than 0.95 must be stored at temperatures below 4°C, but those with a water activity of under 0.95 must be stored at temperatures below 10°C.

##### **c. Heated meat products**

Heated meat products must be stored at temperatures below 10°C. However, this does not apply to products that, after having been packed into air-tight containers, have been sterilized using a method that heats them for 4 minutes at a temperature of 120°C as measured at the center or a method that achieves an equivalent or better effect.

## **D-9 Whale Meat Products**

### **1. Standards for Whale Meat Product Components**

(1) Whale meat products must test negative for coliform bacilli.

(2) Whale meat bacon must not contain nitrite radicals in any amount exceeding 0.070 g per 1 kg.

## **2. Production Standards for Whale Meat Products**

Whale meat products must be produced using a method that complies with the following standards.

- (1) The whale meat used as the raw material for production must be satisfactorily fresh and have minimal microbial contamination.
- (2) Frozen whale meat used as the raw material for production must be thawed out in a hygienic location. When water is used to thaw it out, potable running water must be used.
- (3) The whale meat must be stored in clean and easy-to-wash impermeable containers made of metal, synthetic resin, etc.
- (4) The number of spores must be no more than 1,000 per 1g of the spices, sugar and starch used for production.
- (5) Clean apparatus that is easy to wash and sterilize must be used for production.
- (6) The products must be sterilized using a method that heats them for 30 minutes at a temperature of 63°C as measured at their center areas or a method that achieves an equivalent or better effect.
- (7) After heating and sterilizing, the products must be left to cool sufficiently in a hygienic location. When water is to be used to this end, potable running water or water must be used.

## **3. Storage Standards for Whale Meat Products**

- (1) Whale meat products must be stored at temperatures below 10°C (or below -15°C for frozen whale meat products (defined as whale meat products to be sold as frozen whale meat products). However, this does not apply to products that, after having been filled into air-tight containers, have been sterilized using a method that heats them for 4 minutes at a temperature of 120°C as measured at their center areas or a method that achieves an equivalent or better effect.
- (2) The products must be placed inside clean and hygienic containers and sealed or cased or they must be wrapped in clean and hygienic synthetic resin film, synthetic resin coated paper, parchment paper or paraffin paper for transportation.

## **D-10 Fish-paste Products**

### **1. Standards for Fish-Paste Product Components**

- (1) Fish-paste products (excluding ground fish) must test negative for coliform bacilli.
- (2) Fish sausages and fish ham may not contain silver nitrite in any amount exceeding 0.05 g per 1 kg.

### **2. Production Standards for Fish-Paste Products**

- (1) The fish used for production must be satisfactorily fresh.
- (2) The fish used for production must be thoroughly washed prior to processing, and must be stored in clean and easy-to-wash impermeable containers made of metal, synthetic resin, etc.
- (3) Clean preparation apparatus must be used for the filleting, and the filleted dressed fish meat must be stored in special-purpose, clean and easy-to-wash impermeable containers made of metal, synthetic resin, etc.
- (4) When the dressed fish meat is to be soaked and rinsed, chilled and sanitary water must be used, and the water must be changed sufficiently.
- (5) Frozen fish meat used as the raw material for production must be thawed out in a hygienic location. When water is used to thaw it out, sanitary running water must be used.
- (6) The number of spores must be no more than 1,000 per 1 g of the sugar, starch and spices used for production.
- (7) Clean apparatus that is easy to wash and sterilize must be used for production.
- (8) Fish sausages and fish ham must be sterilized using a method that heats them for 45 minutes at a temperature of 80°C as measured at the center, or a method that achieves an equivalent or better effect; specially wrapped "kamaboko" (white fish meat made into a seasoned paste and steamed) must be sterilized using a method that heats it for 20 minutes at a temperature of 80°C as measured at the center, or a method that achieves an equivalent or better effect; and other fish-paste products must be sterilized using a method that heats them at a steady temperature of 75°C as measured at the center, or a method that achieves an equivalent or better effect. However, this does not apply to ground fish.
- (9) After heating and sterilizing, the products must be left to cool sufficiently in a hygienic

location. When water is to be used for the purposes of cooling, potable running water or water containing at least 1.0 ppm of free residual chlorine must be used, and the water must be changed constantly.

### **3. Storage Standards for Fish-Paste Products**

- (1) Fish sausages, fish ham and specially wrapped "kamaboko" must be stored at temperatures below 10°C. However, this does not apply to products that, after having been packed into air-tight containers, have been sterilized using a method that heats them for 4 minutes at a temperature of 120°C as measured at the center, or a method that achieves an equivalent or better effect, or to products whose pH (defined as the pH obtained for part of a product chopped into small pieces to ten times the amount of purified water has been added, and the whole then ground finely) is less than 4.6 or whose water activity is below 0.94.
- (2) Frozen fish-paste products must be stored at temperatures below -15°C.
- (3) The products must be cased cleanly and hygienically or they must be placed inside clean and hygienic covered containers or wrapped in clean and hygienic synthetic resin film, synthetic resin-coated paper, parchment paper or paraffin paper for transportation.

## **D-11 Salmon Roe and Cod Roe (defined as the ovaries of walleye or pollack preserved in salt; hereafter the same in this section)**

### **1. Standards for Salmon Roe and Cod Roe Components**

Salmon roe and cod roe may not contain silver nitrite radicals in any amount exceeding 0.005 g per 1 kg.

## **D-12 Boiled Octopus**

### **1. Standards for Boiled Octopus Components**

- (1) Boiled octopus must test negative for vibrio parahaemolyticus. The following method shall be used to test for this.

#### **a. Collecting the test specimens and preparing the samples**

Use sterilized apparatus to collect 25 g at random from boiled octopus sliced into thin pieces in a polyethylene bag used for stomaching; add 225 ml of alkaline peptone broth; proceed with stomaching for approximately 30 seconds to one minute; and use the result as the test sample.

Alkaline peptone broth: Dissolve 10 g of peptone and 20 g of sodium chloride in 500 ml of purified water; to this add about 1 mol/l sodium hydroxide solution; adjust the pH to 8.6; add more purified water to total 1,000 ml; and proceed with autoclaving. Same as for Part I: Foodstuffs, Section C: Specific Food Items, Sub-section C14: Fresh Fish and Shellfish to be Eaten Raw, Paragraph 1: Standards for Components of Fresh Fish and Shellfish to be Eaten Raw (limited to fresh fish or shellfish (excluding raw oysters) that has been sliced or shucked and that is to be eaten raw (excluding fresh fish or shellfish that has been frozen)); hereafter the same), Sub-paragraph b-i)

**b. Cultivating the samples and testing for vibrio parahaemolyticus**

- i) Transfer the samples to a container; use a constant-temperature bath for cultivation overnight at 37°C; use a platinum loop to smear a sample from the container onto the TCBS agar medium; cultivate overnight at 37°C; identify the colonies on the medium, which are presumed to be vibrio parahaemolyticus.

TCBS agar medium: Heat and dissolve 5 g of yeast extract, 10 g of peptone, 20 g of saccharose, 10 g of sodium hyposulfite, 10 g of sodium citrate, 3 g of sodium cholate, 5 g of cow's bile powder, 10 g of sodium chloride, 1 g of ferric citrate, 40 mg of bromthymol blue, 40 mg of thymol blue and 15 g of agar in purified water; add about 1 mol/l sodium hydroxide solution, adjust the pH to between 8.5 and 8.7; add more purified water to total 1,000 ml; heat and dissolve. Same as for Part I: Foodstuffs, Section C: Specific Food Items, Sub-section C14: Fresh Fish and Shellfish to be Eaten Raw, Paragraph 1: Standards for Components of Fresh Fish and Shellfish to be Eaten Raw (limited to fresh fish or shellfish (excluding raw oysters) that has been sliced or shucked and that is to be eaten raw (excluding fresh fish or shellfish that has been frozen)); hereafter the same), Sub-paragraph b-i)

- ii) Proceed using a method with equivalent or better performance than that in i)

- (2) Frozen boiled octopus may have a bacterial count (viable cell count) of no more than 100,000 per 1 g of the test specimen, and it must test negative for coliform bacilli. The methods used to determine the bacterial count (viable cell count) and test for coliform bacilli are specified under Part I: Foodstuffs, Section C: Specific Food Items, Sub-section C21: Frozen Foods, Paragraph 1: Standards for Frozen Food Components (limited to produced or processed food (excluding soft drink beverages, meat products, whale meat products, fish-paste products, boiled octopus and boiled crab; hereafter the same in this section) and fresh fish or shellfish (excluding raw oysters; hereafter the same in this section) that have been sliced or shucked and have been frozen and in both cases packed into containers; hereafter the same in this section), Sub-paragraph (1)-a, b and c.

**2. Processing Standards for Boiled Octopus**

- (1) The octopus used for processing must be satisfactorily fresh.
- (2) The water used for the processing must be potable water, sterilized seawater or artificial seawater prepared using potable water.
- (3) After the octopus has been boiled, it must be promptly and sufficiently cooled using potable water, sterilized seawater or artificial seawater prepared using potable water.
- (4) After cooling, the boiled octopus must be packed in clean and easy-to-wash impermeable covered containers made of metal, synthetic resin, etc.

### **3. Storage Standards for Boiled Octopus**

- (1) Boiled octopus must be stored at temperatures below 10°C. Frozen boiled octopus must be stored at temperatures below -15°C.
- (2) The boiled octopus must be packed into clean and hygienic covered containers or wrapped in clean and hygienic synthetic resin film, synthetic resin-coated paper, parchment paper or paraffin paper for transportation.

## **D-13 Boiled Crab**

### **1. Standards for Boiled Crab Components**

- (1) Boiled crab (limited to boiled crab that does not need to be heated when consumed; hereafter the same in (1) below) must test negative for vibrio parahaemolyticus. The following method is used to test for vibrio parahaemolyticus.

#### **a. Collecting the test specimens and preparing the samples**

For boiled crab that is to be sold as meat stripped from the shell, use sterilized apparatus to collect 25 g at random from boiled crab sliced into thin pieces in a polyethylene bag used for stomaching, and use this as the test sample.

For boiled crab that is to be sold in its shell, first disinfect the surface of the shell using cotton dipped in alcohol; using a sterilized apparatus, remove the crab from the shell, slice the crab into thin pieces; collect 25 g at random from these pieces in a polyethylene bag used for stomaching; and use this as the test sample.

The samples must be prepared as specified under Part I: Foodstuffs, Section C: Specific Food Items, Sub-section C12: Boiled Octopus, Paragraph 1: Standards for Boiled Octopus Components, Sub-paragraph (1)-a.

### **b. Cultivating the samples and testing for vibrio parahaemolyticus**

The samples must be cultivated and tested for vibrio parahaemolyticus as specified under Part I: Foodstuffs, Section C: Specific Food Items, Sub-section C12: Boiled Octopus, Paragraph 1: Standards for Boiled Octopus Components, Sub-paragraph (1)-b (2) Frozen boiled crab may have a bacterial count (viable cell count) of no more than 100,000 per 1 g of test specimen, and it must test negative for coliform bacilli. The methods used to determine the bacterial count (viable cell count) and test for coliform bacilli are specified Part I: Foodstuffs, Section C: Specific Food Items, Sub-section C21: Frozen Foods, Paragraph 1: Standards for Frozen Food Components (limited to produced or processed food (excluding soft drink beverages, meat products, whale meat products, fish-paste products, boiled octopus and boiled crab; hereafter the same in this section) and fresh fish or shellfish (excluding raw oysters; hereafter the same in this section) that have been sliced or shucked and have been frozen and in both cases packed into containers; hereafter the same in this section), Sub-paragraph (1)-a, b and c.

## **2. Processing Standards for Boiled Crab (excluding boiled crab that must be heated before consumption and that is not frozen)**

- (1) The crab used for processing must be satisfactorily fresh.
- (2) The water used for processing must be potable water, sterilized seawater or artificial seawater prepared using potable water.
- (3) When the crab is to be heated, it must be heated using a method that heats it for 1 minute at a temperature of 70°C as measured at the center, or a method that achieves an equivalent or better effect.
- (4) After the crab has been heated, it must be promptly and sufficiently cooled using potable water, sterilized seawater or artificial seawater prepared using potable water. In cooling the crab, measures to prevent recontamination from the raw materials, etc. (defined in this section as secondary contamination prevention measures) must be instituted.
- (5) After cooling, secondary contamination prevention measures must be instituted for the boiled crab by placing the crab into clean and easy-to-wash impermeable containers or by a method that achieves an equivalent or better effect.

## **3. Storage Standards for Boiled Crab**

- (1) Boiled crab (limited to boiled crab that does not need to be heated before consumption and that is not frozen) must be stored at temperatures below 10°C.
- (2) Frozen boiled crab must be stored at temperatures below -15°C.
- (3) The boiled crab (excluding boiled crab that needs to be heated before consumption and that is not frozen) must be packed into clean and hygienic containers for storage. However, this

does not apply in cases where secondary contamination prevention measures are instituted before the boiled crab is put on sale).

## **D-14 Fresh Fish and Shellfish to be Eaten Raw**

**1. Standards for Components of Fresh Fish and Shellfish to be Eaten Raw (limited to fresh fish or shellfish (excluding raw oysters) that has been sliced or shucked and that is to be eaten raw (excluding fresh fish or shellfish that has been frozen)); hereafter the same). The most probable number of vibrio parahaemolyticus may be no more than 100 per 1 g of the test specimen. The following method is used to determine the most probable number.**

### **a. Collecting the test specimens and preparing the samples**

Use sterilized apparatus to collect 25 g at random from thinly sliced fish or shellfish in a polyethylene bag used for stomaching; add 225 ml of diluted phosphate buffer solution (with 3% common salt); proceed with stomaching for approximately 30 seconds to one minute; prepare a 10x diluted solution of the test specimen and use this as one of the sample solutions. Next, add 9 ml of the diluted phosphate buffer solution (with 3% common salt) to 1 ml of the 10x diluted solution to create a 100x diluted sample solution; use this as one of the samples. If necessary, also prepare serial diluted solutions of the test specimen as specified for the method used to prepare the 100x diluted solution, and use them as samples.

Diluted phosphate buffer solution (with 3% common salt): Add 3% common salt to the diluted phosphate buffer solution as specified under Part I: Foodstuffs, Section C: Specific Food Items, Sub-section C15: Oysters to be Eaten Raw, Paragraph 1: Standards for Components of Oysters to be Eaten Raw, Sub-paragraph (3)-a.

### **b. Calculating the most probable number of vibrio parahaemolyticus**

- i) Place 1 ml of 10x, 1 ml of 100x and 0.1 ml of the 100x diluted solutions of the test specimen each into three test tubes containing 10 ml of alkaline peptone broth, and use a constant-temperature bath for cultivation overnight at 37°C. After using platinum loops to smear samples from each test tube onto TCBS agar medium and cultivating overnight at 37°C, identify the colonies on the medium, which are presumed to be vibrio parahaemolyticus, and calculate the most probable number from the table below in accordance with the number of positive test tubes whose solutions were diluted in stages.

Table of most probable numbers

No. of positive test tubes			Coefficient	No. of positive test tubes			Coefficient	No. of positive test tubes			Coefficient	No. of positive test tubes			Coefficient
A	B	C		A	B	C		A	B	C		A	B	C	
0	0	0	<3.0	1	0	0	3.6	2	0	0	9.1	3	0	0	23
0	0	1	3.0	1	0	1	7.2	2	0	1	14	3	0	1	39
0	0	2	6.0	1	0	2	11	2	0	2	20	3	0	2	64
0	0	3	9.0	1	0	3	15	2	0	3	26	3	0	3	95
0	1	0	3.0	1	1	0	7.3	2	1	0	15	3	1	0	43
0	1	1	6.1	1	1	1	11	2	1	1	20	3	1	1	75
0	1	2	9.2	1	1	2	15	2	1	2	27	3	1	2	120
0	1	3	12	1	1	3	19	2	1	3	34	3	1	3	160
0	2	0	6.2	1	2	0	11	2	2	0	21	3	2	0	93
0	2	1	9.3	1	2	1	15	2	2	1	28	3	2	1	150
0	2	2	12	1	2	2	20	2	2	2	35	3	2	2	210
0	2	3	16	1	2	3	29	2	2	3	42	3	2	3	290
0	3	0	9.4	1	3	0	16	2	3	0	29	3	3	0	240
0	3	1	13	1	3	1	20	2	3	1	36	3	3	1	460
0	3	2	16	1	3	2	24	2	3	2	44	3	3	2	1100
0	3	3	19	1	3	3	29	2	3	3	53	3	3	3	>1400

Notes:

A = Tube into which 1 ml of the 10x diluted solution of the test specimen was inoculated B = Tube into which 1 ml of the 100x diluted solution of the test specimen was inoculated C = Tube into which 0.1 ml of the 100x diluted solution of the test specimen was inoculated.

- ii) Proceed using a method acknowledged to have a performance equivalent or superior to the method described in i).

## 2. Processing Standards for Fresh Fish and Shellfish to be Eaten Raw

- (1) The water used for the processing must be potable water, sterilized seawater or artificial seawater prepared using potable water.
- (2) The fresh fish and shellfish used as the raw materials must be satisfactorily fresh.
- (3) If the fresh fish and shellfish used as the raw materials have been frozen, they must be thawed out in a hygienic location or thawed out in a clean water bath using potable water, sterilized seawater or artificial seawater prepared using potable water, and the water must be changed sufficiently.
- (4) The fresh fish and shellfish used as the raw materials must be thoroughly washed using

potable water, sterilized seawater or artificial seawater prepared using potable water, and any substances that may possibly contaminate the products must be removed.

- (5) The fresh fish and shellfish, that has been subjected to the washing described in (4) must be processed in a hygienic location other than the location used for that washing. Additives comprising chemical compounds (excluding sodium hypochlorite) must not be used in this processing.
- (6) The apparatus used for the processing must be easy to wash and disinfect. Before use, it must be cleaned and then disinfected.

### **3. Storage Standards for Fresh Fish and Shellfish to be Eaten Raw**

Fresh fish and shellfish must be placed in clean and hygienic containers and stored at temperatures below 10°C.

## **D-15 Oysters to be Eaten Raw**

### **1. Standards for Components of Oysters to be Eaten Raw**

- (1) The bacterial count must be no more than 50,000 per 1 g of the test specimen.
- (2) The most probable number of E. coli must be no more than 230 per 100 g of the test specimen.
- (3) The following methods are used to determine the bacterial count and most probable number of E. coli for oysters to be eaten raw.

#### **a. Collecting the test specimens and preparing the samples**

For oysters to be sold in shucked form, place at least 200 g in a sterilized container using sterilized implements, and use this as the test specimen.

For oysters to be sold in their shells, first disinfect the surfaces of the shells using cotton dipped in alcohol; use sterilized implements to remove the oysters from their shells; collect at least 200 g, including shell juice in a sterilized container, and use this as the test specimen.

Next, transfer the test specimen to the cup of a sterilized homogenizer; add the same quantity of a diluted phosphate buffer solution; crush finely, and use this as the sample solution.

Next, add 80 ml of diluted phosphate buffer solution to 20 ml of the sample solution to prepare a 10x diluted solution of the test specimen; also add 90 ml of diluted phosphate buffer solution to 10 ml of the 10x diluted solution to prepare a 100x diluted solution of the test specimen; use these as the sample solutions. If necessary, also prepare serial diluted solutions of the test

specimen as specified for the method used to prepare the 100x diluted solution, and use them as samples.

Diluted phosphate buffer solution: Dissolve 34 g of monopotassium phosphate (anhydrous) in 500 ml of purified water; add about 175 ml of approximately 1 mol/l sodium hydroxide solution; adjust the pH to 7.2; then add purified water to total 1,000 ml; use this as the stock solution. Add purified water to 1.25 ml of the stock solution to total 1,000 ml, and sterilize under high pressure.

#### **b. Bacterial count (viable cell count) determination method**

From among the samples prepared, select the diluted solution from which 30 to 300 colonies can be cultivated per plate, and determine the bacterial count as specified under Part I: Foodstuffs, Section C: Specific Food Items, Sub-section C3: Crushed Ice, Paragraph 1: Component Standards for Crushed Ice, Sub-paragraph (2)-b.

#### **c. Most probable number of E. coli calculation method**

Place 2 ml of the sample stock solution, 1 ml of the 10x diluted solution and 1 ml of the 100x diluted solution each in five E.C. fermentation tubes, and use a constant-temperature water bath to cultivate the E. coli at 44.5°C (a 0.2°C margin either way is acceptable) for 24 hours (a 2-hour margin either way is acceptable). The sample stock solution or samples found to generate gas at this time shall be considered to have tested positive for E. coli. The most probable number of E. coli for 100 g of the test specimen is obtained by multiplying by 10 the coefficient calculated using the following table (defined hereafter as the most probable number table) in accordance with the number of E.C. fermentation tubes into which sample stock solutions or samples that tested positive for E. coli were inoculated.

(4) The most probable number of vibrio parahaemolyticus in shucked oysters to be eaten raw may be no more than 100 per 1 g of the test specimen. The method used to calculate this number shall be as specified under Part I: Foodstuffs, Section C: Specific Food Items, Sub-section C14: Fresh Fish and Shellfish to be Eaten Raw, Paragraph 1: Standards for Components of Fresh Fish and Shellfish to be Eaten Raw (limited to fresh fish or shellfish (excluding raw oysters) that has been sliced or shucked and that is to be eaten raw (excluding fresh fish or shellfish that has been frozen)); hereafter the same), Sub-paragraph a and b.

## **2. Processing Standards for Oysters to be Eaten Raw**

(1) Oysters used as the raw material must be collected from waters where the most probable number of coliform bacilli is no more than 70 per 100 ml of seawater, or collected from other waters but cleaned using either seawater where the most probable number of coliform bacilli is no more than 70 per 100 ml or artificial salt water with a 3% salinity, while constantly changing or sterilizing the said seawater or artificial salt water.

Method used to measure most probable number of coliform bacilli in seawater: Inoculate 10

ml of seawater collected as the test specimen in five double-concentration lactose broth fermentation tubes, 1 ml of the seawater in five lactose broth fermentation tubes and 0.1 ml of the seawater in five lactose broth fermentation tubes; cultivate at 35°C (a 1.0°C margin either way is acceptable). Seawater in which gas generation is seen after 24 hours (a 2-hour margin either way is acceptable) or after 48 hours (a 3-hour margin either way is acceptable; hereafter the same in this item) is considered to have tested positive in the coliform bacilli presumptive test, and the following confirmation test must be conducted immediately.

Using a platinum loop with a 3 mm diameter, transfer a sample of solution from the double-concentration lactose broth fermentation tubes or lactose broth fermentation tubes that hold seawater that tested positive in the coliform bacilli presumptive test to B.G.L.B fermentation tubes. Cultivate the bacilli at 35°C (a 1.0°C margin either way is acceptable) for 48 hours. Seawater in which gas generation is observed are considered to have tested positive in the coliform bacilli confirmation test. The most probable number of coliform bacilli for 100 ml of the test specimen equals the coefficient calculated using the most probable number table in accordance with the number of double-concentration fermentation tubes that were inoculated with the seawater that, tested positive in the coliform bacilli confirmation test. In the table, "sample solution" refers to "10 ml of the seawater test specimen;" "10x diluted solution of the test specimen" refers to "1 ml of the seawater test specimen;" and "100x diluted solution of the test specimen" refers to "0.1 ml of the seawater test specimen."

- (2) When oysters used as the raw material are to be temporarily stored in water, they must be stored using either seawater in which the most probable number of coliform bacilli is no more than 70 per 100 ml or artificial salt water with a 3% salinity, and the seawater or artificial salt water must be constantly changed or sterilized.
- (3) Oysters used as raw material must be thoroughly washed in sanitary water promptly after they are caught or landed.
- (4) Oysters to be eaten raw must be processed in a hygienic location. Furthermore, additives that are chemical compounds (excluding sodium hypochlorite) may not be used in this processing.
- (5) The water used in shucking the oysters must be potable water, sterilized seawater or artificial seawater prepared using potable water.
- (6) The apparatus used for shucking must be easy to wash and sterilize. Before use, it must be cleaned and then sterilized.
- (7) The containers to be used for the shucked oysters must be easy-to-wash and easy-to-sterilize impermeable containers made of metal, synthetic resin, etc. They must be used exclusively for shucked oysters, and they must be cleaned and then sterilized.

- (8) The shucked oysters must be thoroughly washed in potable water, sterilized seawater or artificial seawater prepared using potable water.
- (9) To produce frozen oysters to be eaten raw, the oysters must be frozen promptly after processing.
- (10) The oyster shells remaining after the processing of the oysters to be eaten raw must be promptly removed to another location or otherwise dealt with, to maintain hygiene in the location where the oysters are processed.

### **3. Storage Standards for Oysters to be Eaten Raw**

- (1) Oysters to be eaten raw must be stored at temperatures below 10°C. However, frozen oysters to be eaten raw must be stored at temperatures below -15°C.
- (2) Oysters to be eaten raw must be packed into clean and hygienic covered containers or wrapped in clean and hygienic composite resin, aluminum foil or water-resistant coated paper for storage. However, frozen oysters to be eaten raw must be wrapped in clean and hygienic composite resin, aluminum foil or water-resistant coated paper for storage.

## **D-16 Agar**

### **1. Standards for Agar Components**

The boron compound content may be no more than 1 g boric acid (H<sub>3</sub>BO<sub>3</sub>) in 1 kg of agar. The following method shall be used to test for boric acid.

#### **Boric acid test method**

Dry out the sample for 3 hours at 100°C until it becomes a powder and weigh out between 25 and 100 g. After moistening in 10% sodium hydroxide solution, evaporate all liquids using a quartz or platinum dish; heat the dried sample in an electric furnace (approx. 500°C) until the organic matter is completely carbonized; cool and then place on another quartz or platinum dish; add about 20 ml of boiling water; mix; and add 10% hydrochloric acid drop by drop until the solution turns obviously acidic. Filter the solution; wash the filter paper in a small amount of boiling water; combine the wash liquid with the filtrate. When doing this, do not allow the amount of liquid to exceed 50 to 60 ml. Transfer the residue still in the filter paper to the quartz or platinum dish; alkalize the residue using lime milk; evaporate to dryness in an aqueous solution; then heat until it burns and turns into ash. Add 5 to 6 ml of 10% hydrochloric acid to dissolve the ash; add the dissolved ash to the mixed liquid created above with the filtrate and the liquid produced from washing the filter paper; add the liquid resulting from washing the quartz or platinum dish in a small amount of water to this liquid and add 0.5 g of calcium chloride and 2 to 3 drops of phenolphthalein sample solution; add 10% sodium hydroxide solution by drops until the liquid turns and remains pink. Next, add lime

milk to total 100 ml, mix well, and filter using a dry filter paper. After adding 0.5 mol/l sulfuric acid to 50 ml of the filtrate until the reddishness of the liquid disappears, add two or three drops of methyl orange sample solution. Add 0.5 mol/l sulfuric acid by drops until the liquid changes from yellow to bright red. Boil for about one minute to remove the carbon dioxide gas; let stand until cool; add 0.1 mol/l sodium hydroxide solution by drops until the liquid turns yellow. To this solution, add 1 to 2 g of neutral mannite or neutral glycerin and 2 to 3 drops of phenolphthalein sample solution; titrate using 0.1 mol/l sodium hydroxide solution until the liquid turns and remains bright red. Add a small amount of the neutral mannite or neutral glycerin, and if the bright red color of the liquid disappears, continue with the titration. In addition, conduct a blank test using the same method. The same quantity of water must be used in place of the mixture of the filtrate and the liquid obtained from washing the filter, and only filter paper may be used, instead of the residue and filter paper.

1 ml of 0.1 mol/l sodium hydroxide solution = 0.0062 g H<sub>3</sub>BO<sub>3</sub>

## D-17 Grains, Beans and Vegetables

### 1. Standards for Grain and Bean Components

The grains and beans listed in Column 1 of the table below may not contain the substances listed in Column 2 in quantities exceeding the respective amounts specified in Column 3 (or equal to or more than the amounts listed in Column 3 for cadmium and its compounds listed in Column 2 of the same table). If any substance listed in Column 2 is specified as "undetectable" in Column 3, it must not be detected at all when tested using the test method in 2 below.

Column 1	Column 2	Column 3
Rice	Cadmium and cadmium compounds	1.0 ppm as Cd
Soybeans	Cyanide compounds	Undetectable
Adzuki beans	Cyanide compounds	Undetectable (but 500 ppm as HCN for saltani beans, saltapia beans, butter beans, pequia beans, white beans and lima beans)
Peas	Cyanide compounds	Undetectable
Broad beans	Cyanide compounds	Undetectable
Peanuts	Cyanide compounds	Undetectable
Other types of beans	Cyanide compounds	Undetectable

## 2. Test methods for Standards for Grain and Bean Components

### (1) Test specimens

Foodstuff	Test specimen
Rice	Unpolished (brown) rice
Peas, adzuki beans, broad beans and soybeans	Beans
Peanuts	Shelled peanuts
Other types of beans	Beans

### (2) Cadmium test method

The atomic absorption method as described in a. below is used to quantify the cadmium. However, the dithizone chloroform method as described in 2. below may be used instead.

#### a. Atomic absorption method

##### i) Equipment

Atomic absorption spectrophotometer  
Light source: Cadmium hollow cathode lamp  
Fuel: Acetylene gas or hydrogen

##### ii) Agents and reagents

Use agents and reagents listed in Part II: Additives, Section C: Regents and Solutions in most cases. Exceptions are listed below.

Cadmium control solution: Dissolve 0.100 g of metal cadmium in 50 ml of 10% nitric acid; boil and add water to total 1,000 ml. Take 10 ml, and add water to total 1,000 ml.  
1 ml of cadmium control solution = 1 µg Cd<sup>2+</sup>

1% diethyldithiocarbamate solution: Dissolve 1 g of sodium diethyldithiocarbamate in water to total 100 ml.

25% potassium sodium tartrate solution: Dissolve 25 g of potassium sodium tartrate in water to total 100 ml.

##### iii) Sample preparation

Put approximately 10 to 30 g of the test specimen into a 300 ml Kjeldahl flask; add 10 to 40 ml of water and 40 ml of nitric acid; mix well and heat gently. After heating for a short while, let stand until cool; add 20 ml of sulfuric acid, and reheat. Add small amounts of nitric acid from time to time if necessary. The decomposition is complete when the contents of the flask turn from a light yellow liquid to a colorless and transparent liquid. After cooling, add water to total 100 ml.

In addition, take the same amount of acid as the acid used for the decomposition, and

follow the same steps to prepare a blank sample solution.

#### iv) Test procedure

Take Vml (an amount less than 50 ml by 0.5 to 20  $\mu\text{g}$ ) of the sample; add 5 ml of a 25% potassium sodium tartrate solution and add two drops of bromothymol blue sample solution. Neutralize with ammonia water until the sample changes from light yellow to a bluish-purple color; add more water to total 100 ml. To this add 10 ml of saturated ammonium sulfate solution; add 5 ml of a 1% diethyldithiocarbamate solution, and let stand for several minutes. Add exactly 10 ml of methyl isobutyl ketone; use a shaker to shake the sample vigorously for about 5 minutes; let stand; separate the methyl isobutyl ketone layer and measure absorbency A at the 228.8 nm wavelength.

In addition, take V'ml (5 to 20 ml) of the cadmium control solution and Vml of the blank sample solution and follow the same steps as with the samples, and measure absorbency  $A_s$  and  $A_o$ .

Determine the cadmium concentration C (ppm) in the test specimen using the following formula.

$$C \text{ (ppm)} = V' \times ((A-A_o)/(A_s-A_o)) \times (\text{total amount of sample solution (ml)/V}) \times (1/\text{amount of test specimen collected (g)})$$

### b. Dithizone chloroform method

#### i) Equipment

Use equipment as specified for the spectrophotometry method in Part II: Additives, Section B: General Testing Methods.

#### ii) Agents and reagents

Use agents and reagents listed in Part II: Additives, Section C: Regents and Solutions in most cases. Exceptions are listed below.

20% hydroxylamine hydrochloride solution: Dissolve 20 g of hydroxylamine hydrochloride in water to total 100 ml.

Cadmium control solution: Dissolve 0.100 g of metal cadmium in 50 ml of 10% nitric acid; boil; add water to total 100 ml. Take 10 ml of this solution, and add water to total 1,000 ml.

1 ml of cadmium control solution = 10  $\mu\text{g}$   $\text{Cd}^{2+}$

Dithizone chloroform solution: Grind the dithizone using a mortar; dissolve 0.05 g of ground dithizone in 100 ml of chloroform (newly distilled chloroform; hereafter the same); add 100 ml of ammonia water solution (1  $\rightarrow$  100); shake and mix; let stand and then remove the water layer. Take the same steps for the chloroform layer twice using 100 ml of ammonia water solution (1  $\rightarrow$  100) each time, put this together with the

water layer, and use 20 ml of the chloroform each time to wash the water layer 3 times. Next, add hydrochloric acid (1 → 2) to the water layer; after turning slightly acidic, use 200 ml of chloroform each time to obtain the extract twice. Put this together with the chloroform layer, add more chloroform to total about 1,000 ml, and use this as the dithizone chloroform stock solution. Protect the stock solution from light, and store in a cool location.

Use the chloroform as a contrast solution, and measure absorbency  $A$  of the solution obtained by diluting 10x the solution with chloroform at the maximum wavelength near the 605 nm wavelength using a 10 mm long layer.

Next, take the solution  $(20,000/(62xA))$  ml, and add chloroform to it to total exactly 1,000 ml.

Prepare before use:

1,000 ml of dithizone chloroform solution = 20 mg  $C_{18}H_{12}N_4S$

- 25% potassium sodium tartrate solution: Dissolve 25 g of potassium sodium tartrate in water to total 100 ml.
- 2% tartaric acid solution: Dissolve 2 g of tartaric acid in water to total 100 ml.
- Sodium hydroxide/potassium cyanide solution: (A) Dissolve 40 g of sodium hydroxide and 1 g of potassium cyanide in water to total 100 ml.
- Sodium hydroxide/potassium cyanide solution: (B) Dissolve 40 g of sodium hydroxide and 0.05 g of potassium cyanide in water to total 100 ml.

### iii) Preparing the samples

Weigh 10 to 30 g of the test specimen into a 300 ml Kjeldahl flask; add 10 to 40 ml of water and 40 ml of nitric acid; mix well and heat gently. After heating for a short while, let stand until cool; add 20 ml of sulfuric acid; heat again. Meanwhile, add small amounts of nitric acid from time to time if necessary. Decomposition is complete when the contents of the flask change from light yellow to colorless and transparent. After cooling, add 25 ml of saturated ammonium oxalate solution; heat until the sulfuric acid gives off white smoke. After cooling, add about 50 ml of water and 2 ml of the 20% hydroxylamine hydrochloride solution. Repeat the extraction, using 10 ml of dithizone chloroform solution each time, until the solution turns and remains dithizone green. After shaking and mixing once or twice with 10 to 20 ml of chloroform, let the solution stand; discard the chloroform layer. Add 5 ml of 25% potassium sodium tartrate solution and 2 drops of methyl orange sample solution to the water layer; neutralize using ammonia water; add water to total 100 ml, and use this as the sample.

### iv) Test procedure

Place 25 ml of the sample in a separating funnel; add 5 ml of 25% potassium sodium tartrate solution, 5 ml of sodium hydroxide/potassium cyanide solution (A), 1 ml of 20% hydroxylamine hydrochloride solution and 10 ml of dithizone chloroform solution; shake and mix for one minute; let the mixture stand; separate the chloroform layer into

another separating funnel into which 25 ml of 2% tartaric acid solution has already been poured. Extract the water layer twice using 10 ml of the dithizone chloroform solution the first time and 5 ml the second time; add the chloroform layer to the chloroform layer that was separated earlier; shake and mix for 2 minutes; let the solution stand; discard the bottom chloroform layer. Wash the water layer using 5 ml of chloroform, and discard the chloroform layer.

Add 1 ml of 20% hydroxylamine hydrochloride solution, 5 ml of sodium hydroxide/potassium cyanide solution (B) and 10 ml of dithizone chloroform solution to the water layer; shake and mix for 1 minute; let the solution stand; filter the bottom chloroform layer using a dry filter paper; and transfer it to a 25 ml measuring flask. Extract the water layer twice using 10 ml of the dithizone chloroform solution the first time and 5 ml the second time; filter the chloroform layer using a dry filter paper; add it to the 25 ml measuring flask, and add chloroform to total 25 ml. Measure absorbency A of this solution at the maximum wavelength near 520 using a 10 mm long layer as specified under Part II: Additives, Section B: General Testing Methods, Paragraph: Operating Procedure for Spectrophotometry.

In addition, take 2 ml of the cadmium control solution, and add water to total 25 ml. Process both this and 25 ml of water in the same way as specified in iii) Preparing the samples and iv) Test procedure above, and measure absorbency  $A_s$  and  $A_o$ . Use chloroform as the contrast solution.

Find the cadmium concentration C (ppm) in the test specimen using the following formula.

$$C \text{ (ppm)} = 20 \times \left( \frac{A - A_o}{A_s - A_o} \right) \times \left( \frac{\text{total amount of sample solution (ml)}}{\text{amount of sample collected (ml)}} \right) \times \left( \frac{1}{\text{amount of test specimen collected (g)}} \right)$$

### (3) Cyanide test method

#### **a. Agents and reagents**

Use agents and reagents listed in Part II: Additives, Section C: Reagents and Solutions in most cases. Exceptions are listed below.

Citrate buffer solution: Dissolve 128.1 g of citric acid and 64.4 g of sodium hydroxide in water to total 1 liter, dilute 10-fold immediately before use, and correct the pH to 5.9 using the citric acid solution and sodium hydroxide solution.

Picric acid paper: Immerse a filter paper in a saturated aqueous solution of picric acid; dry at room temperature; cut the paper so that it is 7 mm by 40 mm and soak in a 10% sodium carbonate solution immediately before use.

#### **b. Qualitative test**

Measure 20.0 g of the crushed test specimen into a 200 ml Erlenmeyer flask; add 50 ml of

citrate buffer solution; tightly stopper the flask using a cork stopper from which the picric acid paper has been suspended; shake and mix gently from time to time at a temperature of 25 to 35°C; let stand for 3 hours. Add 2 g of tartaric acid; immediately stopper the flask tightly with the same cork stopper; apply heat for 1 hour at a temperature of 50 to 60°C while shaking and mixing from time to time. If cyanides are present, the picric acid paper will turn reddish brown.

### **c. Quantitative test**

Add 200 ml of citrate buffer solution to 25.0 g of the crushed test specimen; stopper tightly; after shaking and mixing, let stand for 3 to 5 hours at a temperature of 25 to 35°C. Add 100 ml of water, and proceed with steam distillation. Pour 5 ml of a 5% potassium hydroxide solution into a 200 ml Erlenmeyer flask ahead of time; tilt the container and immerse the bottom end of a cooler in the solution. Distill until the volume equals about 150 ml; add 5 ml of 10% potassium iodide solution to the distillate, and titrate until the 0.05 mol/l silver nitrate solution turns cloudy.

1 ml of 0.05M silver nitrate solution = 2.70 mg HCN

- (4) Any other method with a performance equivalent or superior to the test methods described in (2) and (3)

## **3. Usage Standards for Beans**

Beans in which cyanide is detected may not be used except as raw material for bean jam for further processing.

## **4. Processing Standards for Vegetables**

When potatoes are to be irradiated in order to prevent germination, the following method must be used.

- (1) The source and type of the radiation used must be cobalt-60 gamma rays.
- (2) The dose absorbed by the potatoes must not exceed 150 Gy.
- (3) Potatoes that have already been irradiated must not be irradiated again.

## **D-18 Bean Jam for Further Processing**

### **1. Standards for Bean Jam Components for Further Processing**

No cyanides may be detected in bean jam for further processing. The following method is used to detect cyanides.

Detection method

Place the equivalent of 10 g of dried bean jam for further processing in a 200 ml Erlenmeyer flask, and use the method to detect cyanides as specified under Part I: Foodstuffs, Section C: Specific Food Items, Sub-section C17: Grains, Beans and Vegetables, Paragraph 2: Test Method for Standards for Grain and Bean Components, Sub-paragraph (3): Cyanide Test Method.

## **2. Production Standards for Bean Jam for Further Processing**

When bean jam for further processing is to be produced using beans containing cyanides as the raw material, the following method must be used.

- (1) The beans must be soaked for at least 4 hours using warm water.
- (2) The beans must be boiled long enough after removing tannin at least once.
- (3) After making the bean jam in a bean jam machine, soak thoroughly in water on a water bath at least 3 times.

## **D-19 Soybean Curd ("tofu")**

### **1. Production Standards for Soybean Curd**

- (1) Soybeans used as a raw material must be of good quality and must not contain any foreign elements.
- (2) Soybeans used as a raw material must be thoroughly washed in water.
- (3) Soy juice or soy milk must be sterilized using a method that boils the juice or milk for 2 minutes or a method that achieves an equivalent or better sterilization effect.
- (4) The filtering of the soy juice, addition of the coagulants and molding of the soybean curd must be done cleanly and hygienically.
- (5) The soybean curd must be soaked in water while constantly changing the water.
- (6) The packed soybean curd (defined as that produced by adding coagulants to soy milk, which is then packed in containers and heated so that the milk coagulates) must be sterilized using a method that heats it for 40 minutes at 90°C or a method that achieves an equivalent or better sterilization effect.
- (7) The apparatus used for producing the soybean curd must be thoroughly washed and sterilized.

(8) The water used for producing the soybean curd must be potable water.

## **2. Storage Standards for Soybean Curd**

(1) Soybean curd must be refrigerated or stored in a thoroughly washed and sterilized water bath containing chilled potable water that is constantly changed. However, this does not apply to soybean curd that is sold from the back of trucks or in a similar manner or to soybean curd for which sale immediately after molding, without soaking in water, constitutes the norm.

(2) Soybean curd sold from the back of trucks or in a similar manner must be kept cool using apparatus that has been thoroughly washed and sterilized.

## **D-20 Instant Noodles**

### **1. Standards for Instant Noodle Components (limited to noodles processed using fats and oils)**

The acid value for oils and fats contained in instant noodles may not exceed 3 nor may the peroxide value exceed 30. The following method is used to measure the acid and peroxide values.

#### **a. Agents and reagents**

Use agents and reagents listed in Part II: Additives, Section C: Reagents and Solutions in most cases. Exceptions are listed below.

**Purified ether:** Place the appropriate amount of ether in a separating funnel; add about one-fifth of the ether volume of a 2% ferrous sulfate solution prepared immediately before this use; shake and mix well; discard the water layer. Repeat these steps several times until the water layer of the 2% ferrous sulfate solution is no longer yellowish-brown. After washing 2 or 3 times in water with a volume about one-fifth that of the ether, collect only the ether layer, and add anhydrous sodium sulfate to dehydrate. After dehydration, transfer the ether to a distilling flask; attach a fractionating column; and distill. After discarding about 10% of the initial distillate, collect the distillate until about 10% of the ether in the retort remains; pour into a light-resistant container that can be tightly stoppered; add small amounts each of ferrous sulfate (in crystalline form) and sodium hydroxide (in granular form), and store in a cool, dark location.

**Mixed solution of ethanol and ether (1:2):** Using a phenolphthalein sample solution as the indicator, immediately before use, add 0.1M ethanolic potassium hydroxide solution until the color turns pink and remains pink for 30 seconds.

#### **b. Preparing the samples**

Collect the required quantity of noodles (a quantity appropriate for yielding the samples sufficient to perform the acid number and peroxide number tests); crush or chop the noodles finely; pour them into an Erlenmeyer flask with a ground-in stopper; add enough purified ether to cover the noodles. Let the mixture stand for about 2 hours, shaking and mixing

occasionally; filter using a filter paper to catch the solids in the test specimen; add about half of the quantity of purified ether as was originally added to the test specimen in the flask; shake and mix; filter using the same filter paper. Transfer both filtrates to a separating funnel; add water equal to between about one-half and one-third of the filtered solution; shake and mix well to wash; discard the water layer. After repeating these steps twice, separate the ether layer. After dehydrating the separated ether layer using anhydrous sodium sulfate while allowing nitrogen or carbon dioxide to pass through, remove all the ether under decompression on a water bath at a temperature of less than 40°C, and use the residue as the sample. After pouring the sample into a container that can be tightly sealed and replacing the air with nitrogen, store in an ice chamber.

### **c. Acid value measurement method**

Measure approximately 10 g of the sample; pour it into an Erlenmeyer flask with a ground-in stopper; add 100 ml of the mixed solution of ethanol and ether (1:2) to dissolve it. With a phenolphthalein sample solution as the indicator, titrate using a 0.1 mol/l ethanolic potassium hydroxide solution until the color remains pink for 30 seconds.

Obtain the acid value using the following formula.

$$\text{Acid value} = (5.611 \times a \times F)/S$$

Where, S=Amount (g) of sample collected

a: Consumption amount (ml) of 0.1 mol/l ethanolic potassium hydroxide solution

F: Potency of 0.1 mol/l ethanolic potassium hydroxide solution

### **d. Peroxide value measurement method**

Measure approximately 5 g of the sample into an Erlenmeyer flask with a ground-in stopper; add 35 ml of a mixed solution of chloroform and acetic acid (2:3) to dissolve it. If the sample is not dissolved uniformly, add more of the mixed solution of chloroform and acetic acid (2:3), as necessary. Replace the air inside the flask with nitrogen or carbon dioxide, and while allowing nitrogen or carbon dioxide to pass through, add 1 ml of a saturated potassium iodide solution; immediately secure the ground-in stopper; shake and mix for about one minute; then let stand for about 5 minutes at room temperature in a dark location. Add 75 ml of water; after vigorously shaking and mixing, use a starch sample solution as the indicator and titrate using a 0.01 mol/l sodium thiosulfate solution. In addition, following the same steps, conduct a blank test and correct.

Obtain the peroxide value using the following formula.

$$\text{Peroxide value (meq/kg)} = ((a \times F)/S) \times 10$$

Where, S=Amount (g) of sample collected

a: Consumption amount (ml) of 0.01 mol/l sodium thiosulfate solution

F: Potency of 0.01 mol/l sodium thiosulfate solution

## **2. Storage Standards for Instant Noodles**

Instant noodles must be stored in a location that is not exposed to direct sunlight.

## **D-21 Frozen Foods**

### **1. Standards for Frozen Food Components (limited to produced or processed food (excluding soft drink beverages, meat products, whale meat products, fish-paste products, boiled octopus and boiled crab) and fresh fish or shellfish (excluding raw oysters) that have been sliced or shucked and have been frozen and in both cases packed into containers; hereafter the same in this section)**

- (1) Frozen food to be consumed unheated (defined as food produced or processed and then frozen and that that does not require heating before eating or drinking; hereafter the same in this section) may have a bacterial count (viable cell count) of no more than 100,000 per 1 g of the test specimen, and it must test negative for coliform bacilli.

The following methods are used to determine the bacterial count (viable cell count) and test for coliform bacilli.

#### **a. Collecting the test specimens and preparing the samples**

Thoroughly wipe the surfaces of the still frozen containers with cotton soaked with alcohol; using a sterilized instrument to unseal the containers, finely chop all the contents; randomly collect 25 g; place the sample in an aseptically sterilized homogenizer; add 225 ml of sterilized diluted phosphate buffer solution; crush finely. Using a sterilized pipette, collect 10 ml of the specimen in a sterilized sample jar; add 90 ml of sterilized diluted phosphate buffer solution; mix well, and use this as the sample solution.

To determine the bacterial count (viable cell count), use the sample solution that has been serially diluted with the sterilized diluted phosphate buffer solution in such a way that 30 to 300 colonies can be cultivated per plate; use the sample solution itself as the sample to test for the coliform bacilli.

#### **b. Bacterial count (viable cell count) determination method**

Determine the bacterial count using the method specified under Part I: Foodstuffs, Section C: Specific Food Items, Sub-section C3: Crushed Ice, Paragraph 1: Standards for Crushed Ice Components, Sub-paragraph (2)-b.

#### **c. Coliform bacilli test method**

Test for coliform bacilli using the method specified under Part I: Foodstuffs, Section C: Specific Food Items, Sub-section C4: Frozen Confections, Paragraph 1: Standards for Frozen Confection Components, Sub-paragraph (2)-c.

- (2) Frozen food to be consumed after heating (defined as foods produced or processed and then

frozen, other than frozen food to be consumed unheated; hereafter the same in this section), but also heated immediately before freezing may have a bacterial count (viable cell count) of no more than 100,000 per 1 g of the test specimen, and it must test negative for coliform bacilli. The methods used to determine the bacterial count (viable cell count) and test for coliform bacilli are those specified in a., b. and c. of (1) above.

- (3) Frozen food to be consumed after heating other than food that was heated immediately before freezing may have a bacterial count (viable cell count) of no more than 3,000,000 per 1 g of the test specimen, and it must test negative for E. coli. (However, frozen doughs whose main ingredient is flour and that need to be heated before consumption do not need to test negative for E. coli).

The following methods are used to determine the bacterial count (viable cell count) and test for E. coli.

**a. Collecting the test specimens and preparing the samples**

The collection and preparation are performed as specified in a. of (1) above. The sample solution itself is used as the sample for the E. coli test.

**b. Bacterial count (viable cell count) determination method**

This is determined as specified in b of (1) above.

**c. E. coli test method**

Inoculate 1 ml of the sample in each of three E.C. fermentation tubes (as specified under Part I: Foodstuffs, Section C: Specific Food Items, Sub-section C15: Oysters to be Eaten Raw, Paragraph 1: Standards for Components of Oysters to be Eaten Raw, Sub-paragraph (3)-c, and use a constant-temperature water bath to cultivate the sample at 44.5°C (a 0.2°C margin either way is acceptable) for 24 hours (a 2-hour margin either way is acceptable; hereafter the same in this item). The samples found to generate gas at this time are considered positive for the presumptive test; all other samples are considered negative for this test.

If the samples are positive for the presumptive test, use a platinum loop to streak samples from the E.C. fermentation tubes onto EMB medium, and after cultivation at 35°C (a 1°C margin either way is acceptable; hereafter the same in this item) for 24 hours; swab the typical E. coli colonies (if there are no typical colonies, two or more colonies resembling the typical colonies); transfer samples of each to a lactose broth fermentation tube and agar slant (if colonies resembling the typical colonies have been swabbed, transplant each sample that has been swabbed from each colony to a separate tube and agar slant).

Cultivate the E. coli at 35°C for 48 hours (a 3-hour margin either way is acceptable) when using the lactose broth fermentation tube or at 35°C for 24 hours when using the agar slant. If gas generation is observed in the lactose broth fermentation tube, perform a microscopic test on bacilli cultivated on the corresponding agar slant, and if Gram-negative nonspore-forming bacilli are found, it is considered positive for E. coli.

- (4) Frozen fresh fish and shellfish to be eaten raw (defined as frozen fresh fish and shellfish that has been sliced or shucked, that is to be eaten raw and that has been frozen; hereafter the same in this section) may have a bacterial count (viable cell count) of no more than 100,000 per 1 g of the test specimen; they must test negative for coliform bacilli, and the most probable number of vibrio parahaemolyticus may be no more than 100. The methods used to determine the bacterial count (viable cell count) and test for coliform bacilli are those specified in a., b. and c. of (1) above, and the method used to measure the most probable number of vibrio parahaemolyticus is that specified in Part I: Foodstuffs, Section C: Specific Food Items, Sub-section C14: Fresh Fish and Shellfish to be Eaten Raw, Paragraph 1: Standards for Components of Fresh Fish and Shellfish to be Eaten Raw (limited to fresh fish or shellfish (excluding raw oysters) that has been sliced or shucked and that is to be eaten raw (excluding fresh fish or shellfish that has been frozen)), Sub-paragraph a and b.

## **2. Processing Standards for Frozen Food (limited to frozen fresh fish and shellfish to be eaten raw)**

- (1) Fresh fish and shellfish used as raw materials must be satisfactorily fresh.
- (2) The water used for the processing must be potable water, sterilized seawater or artificial seawater prepared using potable water.
- (3) If fresh fish and shellfish used as raw materials have been frozen, they must be thawed out in a hygienic location or thawed out in a clean water bath using potable water, sterilized seawater or artificial seawater prepared using potable water, and the water must be changed sufficiently.
- (4) Fresh fish and shellfish used as raw materials must be thoroughly washed using potable water, sterilized seawater or artificial seawater prepared using potable water, and any substances that may possibly contaminate the products must be removed.
- (5) Fresh fish and shellfish that has been subjected to the washing described in (4) must be processed in a hygienic location other than the location used for the washing. Additives that are chemical compounds (excluding sodium hypochlorite) may not be used in this processing.
- (6) The apparatus used for the processing must be easy to wash and sterilize. Before use, it must be cleaned and then sterilized.
- (7) The processed fresh fish and shellfish must be frozen promptly after processing.

## **3. Storage Standards for Frozen Food**

- (1) Frozen food must be stored at temperatures below -15°C.
- (2) Frozen food must be wrapped in clean and hygienic composite resin, aluminum foil or water-resistant coated paper for storage.

## **D-22 Food Packed in Containers and Sterilized by Pressurization and Heating**

### **1. Standards for Components of Food Packed in Containers and Sterilized by Pressurization and Heating (defined as food (excluding soft drink beverages, meat products, whale meat products and fish-paste products) that has been packed in air-tight containers, sealed and then subjected to sterilization by pressurization and heating; hereafter the same).**

Food packed in containers and sterilized by pressurization and heating must test negative for all microorganisms that may grow in said food. The following methods are used to test for microorganisms.

#### **(1) Constant-temperature test**

Use the food still in its containers as the test specimen, and keep it for 14 days at 35.0°C (a 1°C margin either way is acceptable); during this period, observe whether the containers expand or swell and whether their contents leak; cool the containers to 20°C and observe them for expansion or swelling; if expansion, swelling or leakage of the containers is observed, the test is considered positive for microorganisms growing in the food. Perform a bacteria test for test specimens that tested negative in the constant-temperature test.

#### **(2) Bacteria test**

##### **a. Preparing the samples**

Using cotton dipped in alcohol, thoroughly wipe the surface of containers of test specimens that tested positive in the constant-temperature test where they are to be opened; open the containers using sterilized instruments; after aseptically mixing the contents (if some or all of the contents are solid, use sterilized scissors to slice them thinly), take 25 g aseptically, add 225 ml of sterilized diluted phosphate buffer solution, and crush finely. Using a sterilized pipette, transfer 1 ml to a sterilized test tube; add 9 ml of sterilized diluted phosphate buffer solution; mix well, and use this as the sample.

##### **b. Test method**

Inoculate 1 ml of the sample into each of five thioglycolate media, and cultivate at 35.0°C (a 1°C margin either way is acceptable) for 48 hours (a 3-hour margin either way is acceptable). The samples are considered to test positive if bacteria are found growing on any of the media.

Thioglycolate media: Add 0.5 g of L-cystine, 5 g of glucose, 5 g of yeast extract, 15 g of peptone, 0.5 g of thioglycolate, 2.5 g of common salt, 0.001 g of resazurin and 0.8 g of powdered agar to 1,000 ml of purified water; heat and dissolve; adjust the pH to 7.0 to 7.2; pour 10 ml into a test tube, and sterilize for 15 minutes at 121°C.

## **2. Production Standards for Food Packed in Containers and Sterilized by Pressurization and Heating**

- (1) Vegetables and other raw materials used for production must be fresh and other quality aspects must be excellent.
- (2) Vegetables and other raw materials used for production must be washed thoroughly if required.
- (3) In the production of food, no additives that are chemical compounds (excluding sodium hypochlorite) used as preservatives or germicidal agents may be used.
- (4) Food packed in containers and sterilized by pressurization and heating, other than canned or bottled foods, must be sealed by hot-melting or rolling.
- (5) The processes of sterilizing, pressurization and heating carried out at the time of production must be done using a sterilizer equipped with a self-recording thermometer, and the records thereof must be kept on file for 3 years.
- (6) A method for the sterilizing processes through pressurization and heating carried out at the time of production must be established to meet the following two conditions, and the processes must be implemented using the established method.
  - a. The method must be satisfactorily effective in destroying the microorganisms that originate in the raw materials, etc., exist in the said food and may possibly grow.**
  - b. For food packed in containers and sterilized by pressurization and heating whose pH exceeds 4.6 and whose water activity exceeds 0.94, either a method that heats the food at a temperature of 120°C as measured at the center for 4 minutes or a method that achieves an equivalent or better effect must be used.**
- (7) When water is to be used for cooling after sterilizing by pressurization and heating, potable running water or water containing at least 1.0 ppm of free residual chlorine must be used and, in the latter case, the water must be changed constantly.
- (8) The apparatus used for production must be thoroughly washed and then sterilized.

## **II. Standards and Testing Methods for Implements, Containers and Packaging**

Ministry of Health, Labour and Welfare

<http://www.mhlw.go.jp/english/topics/foodsafety/index.html> (in English)

<Implements, Containers and Packaging>

<http://www-bm.mhlw.go.jp/topics/bukyoku/iyaku/kigu/dl/4.pdf> (Japanese only)

### **A. Standards for General Implements, Containers, Packaging, and Component Materials**

#### **A-1**

Implements must not be of such a structure that any copper, lead, or alloys thereof can be scraped off.

#### **A-2**

The lead content of any tin plating that comes into contact with food may be no more than 0.1%.

#### **A-3**

Implements, containers or packaging that comes into contact with food must not be manufactured or repaired using any metal with a lead content of more than 0.1% or with an antimony content of more than 5%.

#### **A-4**

Solder used in the manufacture or repair of any implement, container or packaging that comes into contact with food must have a lead content of not more than 0.2%.

#### **A-5**

Implements, containers, and packaging must not contain any synthetic coloring agent not listed in Table 1 of the Implementation Regulations of the Food Sanitation Act. However, this restriction does not apply in cases in which the product in question is processed in such a way as to preclude the coloring agent dissolving or leaching into contact with the food.

#### **A-6**

The electrodes of equipment having a device that induces an electrical current directly into food must not be made of any metal other than iron, aluminum, platinum, or titanium.

However, electrodes made of stainless steel may be used if the current flowing into the food is a small one.

## **A-7**

Implements, containers, and packaging contacting oily or fatty foods must not be made of synthetic resin comprising primarily polyvinyl chloride made with bis(2-ethylhexyl) phthalate. However, this restriction does not apply in cases in which the product in question is processed in such a way as to preclude bis (2-ethylhexyl) phthalate dissolving or leaching into contact with the food.

## **B. Testing Methods for General Implements, Containers, and Packaging**

Except when specified below, the methods specified under Part II: Additives, Section B: General Testing Methods are to be used. In place of a specified method, an alternative method may be used if said method provides equal or greater precision than the specified method. However, if the results obtained are doubtful, the final decision is to be made according to the specified method.

### **B-1: Testing Method for Potassium Permanganate Consumption**

The purpose of the testing method for potassium permanganate consumption is to determine, by the prescribed method, the amount of a material that is oxidized by potassium permanganate after having dissolved a sample into water.

#### Testing Procedure

Into a triangular flask, add 100 ml of water, 5 ml of sulfuric acid (1→3), and 5 ml of 0.002 mol/l potassium permanganate. Boil for 5 minutes, then discard the solution and wash the flask with water. Into the same triangular flask, add 100 ml of sample solution, 5 ml of sulfuric acid (1→3), and 10 ml of 0.002 mol/l potassium permanganate, and boil for 5 minutes. Immediately after stopping heating, add 10 ml of 0.005 mol/l sodium oxalate to decolorize the solution, and titrate with 0.002 mol/l potassium permanganate until a slight red color remains in the solution without fading away. Separately, conduct a blank test and calculate the amount of potassium permanganate consumed using the following formula.

$$\text{Potassium permanganate consumed } (\mu\text{g/ml}) = [(a - b) \times 0.316 \times f \times 1,000]/100$$

Where, a = Amount (ml) of titrated 0.002 mol/l potassium permanganate in the actual test  
b = Amount (ml) of titrated 0.002 mol/l potassium permanganate in the blank test  
f = Factor for 0.002 mol/l potassium permanganate

## B-2 Strength and Other Tests

### Sustained Pressure Test

Fill the container to 95% capacity by volume with diluted sulfuric acid (the type made for sustained pressure testing), then, taking care not to touch the solution, add 1.5 g of sodium bicarbonate for each 100 ml of diluted sulfuric acid (the type made for sustained pressure testing), seal the container and allow the sodium bicarbonate to dissolve. Place the container in water heated to  $45\pm 2^\circ\text{C}$ . Leave for 2 hours and then check for any gas leakage.

### Sustained Decompression Test

Fill the container with water heated to the same temperature as the product when placed into the container, and immediately seal. Place the container in a methylene blue solution (the type made for pinhole testing) heated to  $25\pm 5^\circ\text{C}$ . Leave for 2 hours, empty the container and rinse with water.

Use a pipette to transfer 25 ml of the water in the container to a 50 ml Nessler tube. View the Nessler tube from the top and sides against a white background and check for methylene blue coloring.

### Pressure Test

Make a hole 5 to 10 mm in diameter in a sealed container and insert an air nozzle in such a way that no air leaks out. To this directly connect a pressure gauge and a compressor. Turn on the compressor and set the pressure to 294 kPa and check for air leakage.

### Compression Test

Place a sealed container filled with its contents or water as shown in Figure A. For a container having the total weight shown in Column 1 of the table below, place the weight shown in Column 2 on it for one minute, then check for leakage of the contents or water. Box-shaped containers should be placed as shown in Figure B.

Figure A

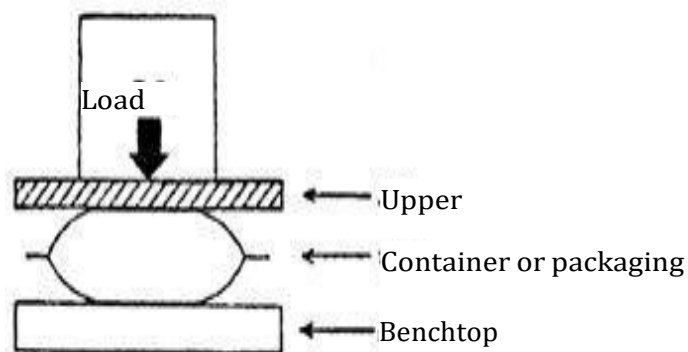
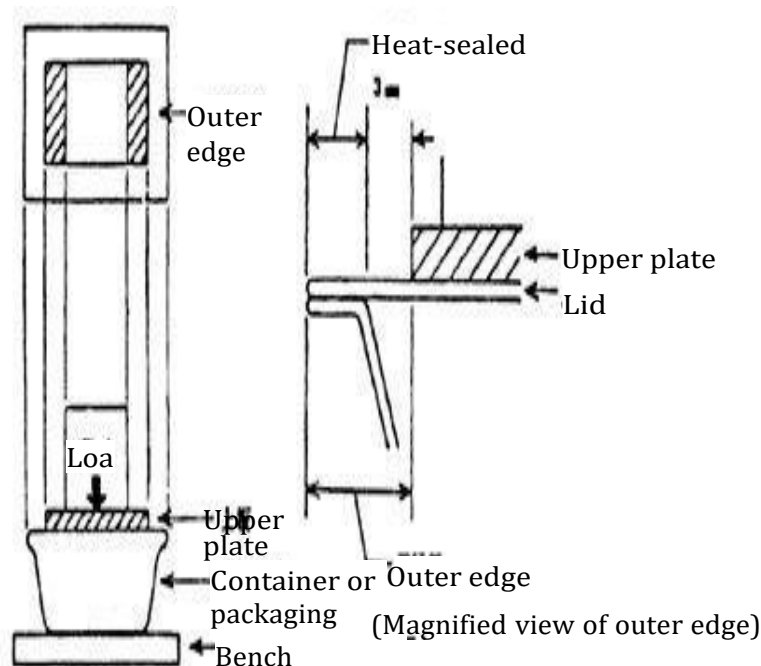

Figure B



Column 1	Column 2
Less than 100g	20kg
100 g or more and less than 400 g	40kg
400 g or more and less than 2,000 g	60kg
2,000 g or more	80kg

### Decompression Test

Insert a vacuum gauge needle into a sealed container or package and secure it to prevent air leakage, and connect a vacuum pump to the needle. Turn on the vacuum pump and decompress to 26.7 kPa, and check whether any air leakage occurs.

### Puncture-Resistance Test

Secure a sample and, with a hemispherical needle 1.0 mm in diameter and having a tip radius of 0.5 mm, poke the sample surface at a rate of  $50 \pm 5$  mm per minute to determine the maximum load at which the needle pierces the surface.

### Internal Pressure-Resistance Test

Insert a needle into the package filled with ingredients or water, secure the sample without any air leaking out of the package and connect a pressure gauge and a compressor to the needle. Using the compressor, feed air into the package at a rate of  $1 \pm 0.2$  L per minute to determine the pressure at which the package ruptures.

### Heat-Seal Test

As shown in the figure below, cut open the heat-sealed portion of a sealed container or package, pull apart both ends of the opening at a rate of  $300 \pm 20$  mm per minute to determine the

maximum load at which the heat-sealed portion separates.

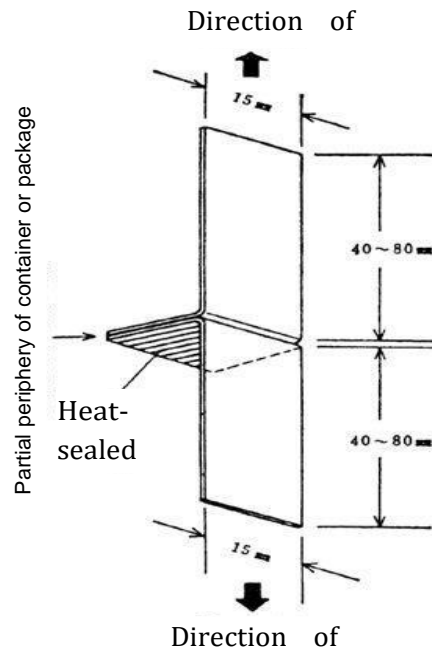

**Burst-Resistance Test**

Secure a sample as shown in the figure and pump glycerin into the pressure chamber at a rate of  $95 \pm 10$  ml per minute to generate pressure to determine the maximum pressure at which the sample bursts.

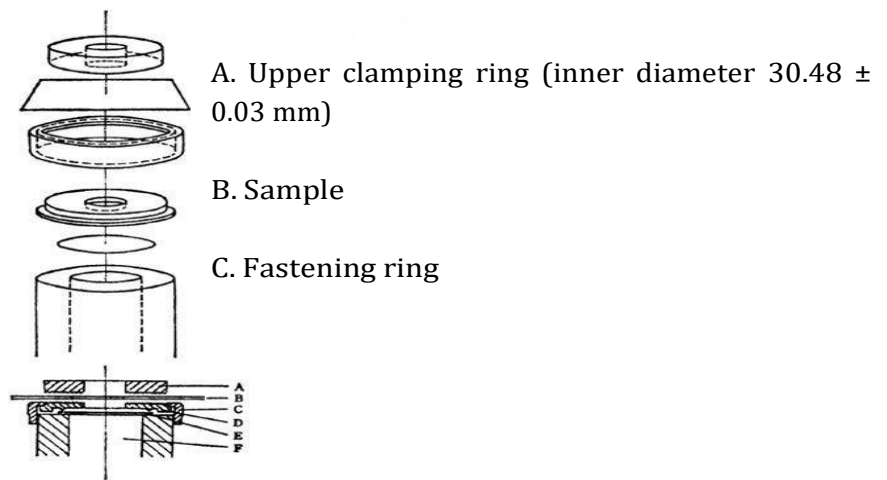

**Pinhole Test**

Fill the container or package with methylene blue solution (the type made for pinhole testing) and leave for 30 minutes, then check for pinholes.

**Seal Test**

Make a hole of 5 to 10 mm in diameter at the center of the side or bottom of a sealed container or package and insert an air nozzle in such a way that no air leaks out. To this directly connect a pressure gauge and a compressor. Turn on the compressor and set the pressure to 13.3 kPa

for 10 seconds and check for air leakage.

### Drop Test

Fill a container or package with its contents or water and seal. For a container or package having the total weight shown in Column 1 of the table below, drop the container twice from the height shown in Column 2 onto a concrete surface so that the container or package lands on its bottom or another flat surface. Check the container or package for leakage of the contents or water.

Column 1	Column 2
Less than 100 g	80cm
100 g or more and less than 400 g	50cm
400 g or more and less than 2,000 g	30cm
2,000 g or more	25cm

### Leakage Test

Place a sealed container or package filled with its contents in a thermostatic bath heated to  $45\pm 2^{\circ}\text{C}$ , laying the container or package on its side. Leave in the bath for 24 hours, and check for leakage of contents.

## B-3 Atomic Absorption Spectrometry

Atomic absorption spectrometry is a technique for determining the concentration of a target element in a sample solution by utilizing the phenomenon in which ground-state atoms absorb light of a characteristic wavelength when light is passed through an atomic vapor layer.

### Equipment

Normally, an atomic absorption spectrometer consists of a light source, a sample atomizer, a spectrometer, a photometer, and a display and recording unit. A hollow cathode lamp is used as the light source. A frame-type (i.e., direct-injection) atomizer consists of a burner and a gas-flow adjuster; an electric heater-type atomizer consists of an electric heating unit and a power source. The spectrometer uses either a diffraction grating or an interference filter. The photometer consists of a detector and a signal processor. The display and recording unit typically includes a display and recording unit.

### Standard solution

Use a standard solution appropriate for the target element, in addition to following any other applicable provisions.

### Procedure

Follow either of the procedures as appropriate, in addition to any other applicable provisions.

### **(1) Frame-type (i.e., direct-injection) atomizer**

Turn on the light source (use a hollow cathode lamp appropriate for the target element) and adjust the spectrometer to the appropriate wavelength for the target element. Set the device to the appropriate current and slit width, then light the gas (use acetylene or hydrogen). Adjust the flow of the gas and compressed air, then spray the solvent mist into the frame and calibrate. Spray the sample solution and the standard solution for the target element into the frame and measure the spectral absorbance.

### **(2) Electric heater-type atomizer**

Turn on the light source (use a hollow cathode lamp appropriate for the target element) and adjust the spectrometer to the appropriate wavelength for the target element. Set the device to the appropriate current and slit width, then place the specified amount of sample solution or standard solution for the target element into the electric heater. Release an appropriate amount of flow gas and, after drying and ashing in the appropriate heating mode, at the appropriate temperature, and for the appropriate amount of time, atomize the ash and measure the spectral absorbance.

When measuring spectral absorbance, use the following wavelengths: zinc 213.9 nm, antimony 217.6 nm, cadmium 228.8 nm, germanium 265.2 nm, lead 283.3 nm, and barium 553.6 nm.

The spectral absorbance of the sample solution must not exceed that of the sample solution for the target element when analyzed in the same manner as the sample solution.

## **B-4 Heavy Metal Test**

The heavy metal test is a technique to determine whether a sample releases an amount of heavy metals that exceeds the allowable maximum. For the purposes of this test, —heavy metal|| refers to metallic substances that exhibit a dark color when exposed to the acidity of a sodium sulfide reagent. The quantity is indicated as the quantity of lead (Pb).

### **Procedure**

Place 20 ml of sample solution in a Nessler tube, and to this add enough water to bring the total volume to 50 ml. In a separate Nessler tube, place 2 ml of lead standard solution (for heavy metal testing) and 20 ml of leaching solution and enough water to bring the total volume to 50 ml; this is the control solution. To both solutions add two drops each of sodium sulfide reagent and leave for 5 minutes, then view both Nessler tubes from the top and sides against a white background. The sample solution should not appear darker in color than the control solution. If the leaching solution used is water, add 5 ml of 4% acetic acid to the sample solution and the lead standard solution, then add enough water to bring the total volume to 50 ml.

## B-5 Evaporation Residue Test

The evaporation residue test is a test to determine the amount of substances that are transported from the sample into a leaching solution.

### Procedure

In addition to following any other applicable provisions, perform the following test for implements, containers, or packaging that directly contact food listed in Column 1 of the following table. Prepare the sample solution using the solvent listed in Column 2 as the leaching solution.

Column 1	Column 2
Oily or fatty food	Heptane
Alcoholic beverage	20% ethanol
Food other than oily or fatty food and alcoholic beverage	
Foods with a pH over 5	Water
Foods with a pH of 5 or less	4% acetic acid

Place 200–300 ml of sample solution (if using heptane as the leaching solution, transfer 200–300 ml of sample solution to an egg-shaped flask, vacuum-concentrate to several milliliters, then rinse this concentrate and the flask twice with approximately 5 ml of heptane and use this wash liquid as the sample solution) in a dry platinum, quartz, or heat-resistant glass evaporation dish of known weight preheated to 105°C, then heat it on a water bath until the solution evaporates and the residue hardens.

After drying for 2 hours at 105°C, let cool in a desiccator. After cooling, weigh the evaporation dish and determine the weight difference  $a$  (mg) before and after evaporation, then use the following equation to calculate the amount of evaporation residue.

$$\text{Evaporation residue } (\mu\text{g/ml}) = [(a - b) \times 1,000] / \text{amount of sample solution used (ml)}$$

Where,  $b$  = Blank test value (mg) obtained for the same amount of leaching solution as the sample solution

## B-6 Additive Tests

### Amines (limited to triethylamine and tributylamine only)

#### (1) Plotting an analytical curve

Accurately measure approximately 10 mg each of triethylamine and tributylamine and place in a 100 ml measuring flask, then add enough dichloroethane to bring the total volume to 100 ml. Next, place 4 ml of this solution in a 100 ml measuring flask, and add enough

dichloroethane to bring the total volume to 100 ml. In separate 20 ml measuring flasks, place 1 ml, 2 ml, 3 ml, 4 ml, and 5 ml of this solution, then add enough dichloroethane to bring the total volume to 20 ml. These are the standard solutions (0.2 µg/ml, 0.4 µg/ml, 0.6 µg/ml, 0.8 µg/ml, and 1.0 µg/ml). Using 1 µl of each standard solution, perform gas chromatography according to the procedure and conditions specified below. Use the resultant gas chromatogram to calculate the height and area of the triethylamine and tributylamine peaks, then plot an analytical curve for each.

### Procedure and conditions

Column	Use a 30 m long silicate-glass column with an inner diameter of 0.32 mm and with a 5 µm thick dimethylpolysiloxane coating.
Column temperature	Heat the column at 150°C for 5 minutes, then raise the temperature by 20°C every minute until 250°C is reached, then maintain at that temperature for 5 minutes.
Sample solution inlet temperature	200°C
Detector	Use an alkaline flame thermionic detector or a high-sensitivity nitrogen phosphorus detector. Operate at or near 250°C. Adjust the flow of air and hydrogen for maximum detection sensitivity.
Insertion method	Spritzer (15:1)
Carrier gas	Use helium. Adjust the flow rate so that the triethylamine flows out in 3–4 minutes.

### (2) Test

Using 1 µl of the sample solution, perform gas chromatography according to the same procedure and conditions as described in subsection (1) above. Use the resultant gas chromatogram to calculate the height and area of each peak. Next, use the respective analytical lines to determine the concentration of triethylamine and tributylamine in the sample solution, and use the following equation to determine the content of each in the material.

Content (µg/g) in the material = sample solution concentration (µg/ml) × 2 (ml) / sample weight (g)

## Tricresyl phosphates

### (1) Qualification Test

Using 20 µl each of sample solution and tricresyl phosphate standard solution, perform liquid chromatography according to the procedure and conditions described below, then compare the peak detection time in the liquid chromatogram of the sample solution to the peak detection time in the liquid chromatogram of the tricresyl phosphate standard solution.

#### Procedure and conditions

Column fill gas	Use phenyl silica gel.
Column	Use a stainless-steel tube 250 mm long and with an inner diameter of 4.6 mm
Column temperature	50°C
Detector	Use an ultraviolet spectrophotometric detector. Operate at a wavelength of 264 nm.
Moving phase	Use a 2:1 mixture of acetonitrile and water. Adjust the flow rate so that the tricresyl phosphate flows out in approximately 9 minutes.

### (2) Quantification Test

Perform the following test if, in the qualification test (1), the peak detection time in the liquid chromatogram of the sample solution matches the peak detection time in the liquid chromatogram of the tricresyl phosphate standard solution.

Using the results obtained under the same procedure and conditions as the qualification test (1) as a reference point, measure the peak area of the tricresyl phosphate in the sample solution. This area should not be greater than the peak area of the tricresyl phosphate standard solution.

## Dibutyltin compounds

### (1) Qualification Test

Take 2 ml each of the sample solution and dibutyltin standard solution and add 5 ml of acetic acid-sodium acetate buffer solution and 1 ml of sodium tetraethylborate reagent, then seal immediately and shake vigorously for 20 minutes. Leave the mixture for approximately 1 hour at room temperature, and remove the hexane layer. Using 1 µl of each, perform gas chromatography and mass spectrometry under the procedure and conditions specified below, then compare the peak detection time in the gas chromatogram of the sample solution with that of the gas chromatogram of the dibutyltin standard solution.

## Procedure and conditions

Column	Use a 30 m long silicate-glass column with an inner diameter of 0.25 mm and with a 0.25 µm thick dimethylpolysiloxane coating containing up to 5% diphenylpolysiloxane.
Column temperature	Heat the column at 45°C for 4 minutes, then raise the temperature by 15°C every minute until 300°C is reached, then maintain at that temperature for 10 minutes.
Sample solution inlet temperature	250°C
Detector	Use a mass spectrometer set to an atomic mass number of 263.
Carrier gas	Use helium. Adjust the flow rate so that the dibutyltin inductor flows out in approximately 13 minutes.

### (2) Quantification Test

Perform the following test if, in the qualification test (1), the peak detection time in the gas chromatogram of the sample solution matches the peak detection time in the gas chromatogram of the dibutyltin standard solution.

Using the results obtained under the same procedure and conditions as the qualification test (1) as a reference point, measure the peak area of the dibutyltin in the sample solution. This area should not be greater than the peak area of the dibutyltin standard solution.

## B-7 Arsenic Test

The arsenic test is a technique to determine whether a sample contains an amount of arsenic that exceeds the allowable maximum. The quantity is indicated as the quantity of arsenic trioxide.

## Equipment

The figure below is a schematic of the equipment used.

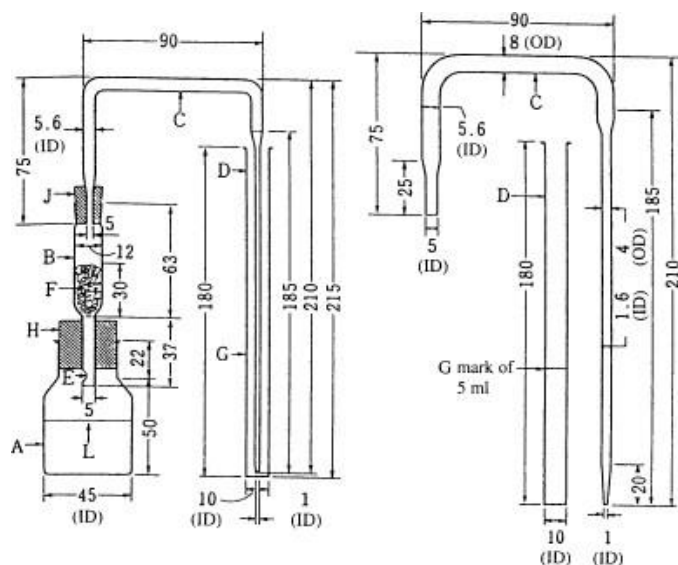

- A: Reaction bottle (capacity to shoulder: approximately 70 ml)
- B: Exhaust tube
- C: Glass tube (inner diameter: 5.6 mm; inner diameter of tip of portion inserted into absorption tube: 1 mm)
- D: Absorption tube (inner diameter: 10 mm)
- E: Hole
- F: Glass fiber (approximately 0.2 g)
- G: 5 ml graduation line
- H & J: Rubber stopper
- L: 40 ml graduation line

Stuff glass fiber (F) in the exhaust tube (B) to a height of approximately 30 mm. After wetting uniformly with an equal mixture of lead acetate reagent and water, apply weak suction from the bottom to remove any excess fluid. Insert the tube vertically through the center of the rubber stopper (H) and into the reaction bottle (A) so that the small hole (E) is just below the bottom of the stopper. To the top of B, affix the rubber stopper (J) in which a glass tube (C) is vertically inserted. The bottom of the exhaust tube side of C should be aligned with the bottom of the rubber stopper (J).

## Procedure

Pour the sample solution into the reaction bottle and add one drop of bromophenol blue, then neutralize with ammonia water or ammonia reagent. The neutralization step may be omitted when the leaching agent is water. To this liquid, add 5 ml of hydrochloric acid (1→2) and 5 ml of potassium iodine. Wait 2–3 minutes, add 5 ml of tin (II) chloride and leave for 10 minutes at room temperature. Next, add enough water to bring the total volume to 40ml, add 2 g of zinc (arsenic test type) and immediately affix rubber stopper H connecting B and C. Insert the narrow tip of C so that it reaches the bottom of absorption tube D, which should already

contain 5 ml of hydrogen arsenide absorbing solution.

Next, place the reaction bottle in 25°C water up to the shoulder and leave for 1 hour. Remove the absorption tube and, if necessary, add enough pyridine to bring the total volume to 5 ml. The absorbing solution must not appear darker in color than the standard color, described below.

To determine the standard color, perform the same procedure as was done for the sample solution. Place the same amount of leaching solution as the sample solution and 2.0 ml of arsenic standard solution into the reaction bottle. The color exhibited by the absorbing solution that results after following the same procedure (described below) as with the sample solution is the standard color.

## **B-8 Monomer Tests**

### **Epichlorohydrine**

#### **(1) Qualification Test**

Using 5 µl each of sample solution and epichlorohydrine standard solution, perform gas chromatography according to the procedure and conditions described below, then compare the peak detection time in the gas chromatogram of the sample solution to the peak detection time in the gas chromatogram of the tricresyl phosphate standard solution.

#### **Procedure and conditions**

Column	Use a 30 m long silicate-glass column with an inner diameter of 0.53 mm and with a 1 µm thick polyethylene coating.
Column temperature	Heat the column at 50°C for 5 minutes, then raise the temperature by 10°C every minute until 100°C is reached.
Sample solution inlet temperature	220°C.
Detector	Use a hydrogen flame ionization detector. Operate at or near 220°C. Adjust the flow of air and hydrogen for maximum detection sensitivity.
Carrier gas	Use nitrogen or helium. Adjust the flow rate so that the epichlorohydrine flows out in approximately 7 minutes.

#### **(2) Quantification Test**

Perform the following test if, in the qualification test (1), the peak detection time in the gas chromatogram of the sample solution matches the peak detection time in the gas chromatogram of the epichlorohydrine standard solution.

Using the results obtained under the same procedure and conditions as the qualification test (1) as a reference point, measure the peak area of the epichlorohydrine in the sample solution. This area should not be greater than the peak area of the epichlorohydrine standard solution.

### **Vinylidene Chloride**

#### **(1) Qualification Test**

Pour 50 µl of vinylidene chloride standard solution into a septum-stoppered glass bottle

already containing 2.5 ml of N,N-dimethylacetamide, and immediately seal. Next, heat sealed glass bottles containing the sample solution and standard solution for 1 hour, shaking occasionally while maintaining at 90°C. Next, using 0.5 ml of vapor from each, perform gas chromatography under the procedure and conditions specified below, then compare the peak detection time in the gas chromatogram of the sample solution with that of vinylidene chloride in the gas chromatogram of the vinylidene chloride standard solution.

**Procedure and conditions**

Column	Use a 25 m long silicate-glass column with an inner diameter of 0.25 mm and with a 3 µm thick coating of porous styrene divinylbenzene resin.
Column temperature	Heat the column at 80°C for 1 minute, then raise the temperature by 10°C every minute until 250°C is reached, then maintain at that temperature for 10 minutes.
Sample solution inlet temperature	200°C.
Detector	Use a hydrogen flame ionization detector. Operate at or near 250°C. Adjust the flow of air and hydrogen for maximum detection sensitivity.
Carrier gas	Use nitrogen or helium. Adjust the flow rate so that the vinylidene chloride flows out in approximately 9 minutes.

**(2) Quantification Test**

Perform the following test if, in the qualification test (1), the peak detection time of vinylidene chloride in the gas chromatogram of the sample solution matches the peak detection time in the gas chromatogram of the vinylidene chloride standard solution.

Using the results obtained under the same procedure and conditions as the qualification test (1) as a reference point, measure the peak area of the vinylidene chloride in the sample solution. This area should not be greater than the peak area of the vinylidene chloride standard solution.

**Vinyl Chloride**

**(1) Qualification Test**

Pour 50 µl of vinyl chloride standard solution into a septum-stoppered glass bottle already containing 2.5 ml of N,N-dimethylacetamide, and immediately seal. Next, heat sealed glass bottles containing the sample solution and standard solution for 1 hour, shaking occasionally while maintaining at 90°C. Next, using 0.5 ml of the vapor from each, perform gas chromatography under the procedure and conditions specified below, then compare the peak detection time in the gas chromatogram of the sample solution with the peak detection time of vinyl chloride in the gas chromatogram of the vinyl chloride standard solution. In the metal can test, place 10 ml of sample solution in a septum-stoppered glass bottle and seal immediately. Place 50 µl of vinyl chloride standard solution in a septum-stoppered glass bottle already containing 10 ml of ethanol, and seal immediately. Maintaining the sealed glass bottles of the sample solution and standard solution at 50°C, heat for 30 minutes, shaking occasionally, and use these to perform the same procedure.

### Procedure and conditions

Column	Use a 25 m long silicate-glass column with an inner diameter of 0.25 mm and with a 3 $\mu\text{m}$ thick coating of porous styrene divinylbenzene resin.
Column temperature	Heat the column at 80°C for 1 minute, then raise the temperature by 10°C every minute until 250°C is reached, then maintain at that temperature for 10 minutes.
Sample solution inlet temperature	200°C.
Detector	Use a hydrogen flame ionization detector. Operate at or near 250°C. Adjust the flow of air and hydrogen for maximum detection sensitivity.
Carrier gas	Use nitrogen or helium. Adjust the flow rate so that the vinyl chloride flows out in approximately 5 minutes.

#### (2) Quantification Test

Perform the following test if, in the qualification test (1), the peak detection time in the gas chromatogram of the sample solution matches the peak detection time in the gas chromatogram of the vinyl chloride standard solution.

Using the results obtained under the same procedure and conditions as the qualification test (1) as a reference point, measure the peak area of the vinyl chloride in the sample solution. This area should not be greater than the peak area of the vinyl chloride standard solution.

### Caprolactam

#### (1) Qualification Test

Using 1  $\mu\text{l}$  each of sample solution and caprolactam standard solution, perform gas chromatography according to the procedure and conditions described below, then compare the peak detection time in the gas chromatogram of the standard solution to the peak detection time of caprolactam in the gas chromatogram of the caprolactam standard solution.

#### Procedure and conditions

Column	Use a 30 m long silicate-glass column with an inner diameter of 0.32 mm and with a 5 $\mu\text{m}$ thick dimethylpolysiloxane coating.
Column temperature	240°C.
Sample solution inlet temperature	240°C.
Detector	Use a hydrogen flame ionization detector. Operate at or near 240°C. Adjust the flow of air and hydrogen for maximum detection sensitivity.
Carrier gas	Use nitrogen or helium. Adjust the flow rate so that the caprolactam flows out in approximately 5 minutes.

#### (2) Quantification Test

Perform the following test if, in the qualification test (1), the peak detection time in the gas chromatogram of the sample solution matches the peak detection time of caprolactam in the gas chromatogram of the caprolactam standard solution.

Using the results obtained under the procedure and conditions as the qualification test (1) as a

reference point, measure the peak area of caprolactam in the sample solution. This area should not be greater than the peak area of the caprolactam standard solution.

## Volatile Substances

### (1) Plotting an analytical curve

Place 90 ml of tetrahydrofuran in a 100 ml measuring flask. Accurately measure and add 50 mg each of styrene, toluene, ethylbenzene, isopropyl benzene, and propyl benzene, then add enough tetrahydrofuran to bring the total volume to 100 ml. In separate 20 ml measuring flasks, place 1 ml, 2 ml, 3 ml, 4 ml, and 5 ml of this solution, and add 1 ml of diethylbenzene sample solution and enough tetrahydrofuran to bring the total volume to 20 ml. These are the standard solutions. Using 1  $\mu$ l of each standard solution, perform gas chromatography according to the procedure and conditions specified below. Use the resultant gas chromatogram to calculate the ratio of the each peak area of styrene, toluene, ethylbenzene, isopropyl benzene and propyl benzene to that of diethylbenzene, then plot an analytical curve for each.

### Procedure and conditions

Column	Use a 30 m long silicate-glass column with an inner diameter of 0.25 mm and with a 0.5 $\mu$ m thick coating of polyethylene glycol.
Column temperature	From a temperature of 60°C, raise the temperature at a rate of 4°C per minute until 100°C is reached, then continue raising the temperature at a rate of 10°C per minute until 150°C is reached.
Sample solution inlet temperature	220°C.
Detector	Use a hydrogen flame ionization detector. Operate at or near 220°C. Adjust the flow of air and hydrogen for maximum detection sensitivity.
Carrier gas	Use nitrogen or helium. Adjust the flow rate so that the diethylbenzene flows out in approximately 11 minutes.

### (2) Test

Using 1  $\mu$ l of the sample solution, perform gas chromatography according to the same procedure and conditions as described in (1) Plotting an analytical curve. Use the resultant gas chromatogram to calculate the ratio of each peak area to that of diethylbenzene. Next, use the respective analytical lines to determine the concentration of styrene, toluene, ethylbenzene, isopropyl benzene, and propyl benzene, then use the following equation to determine the content of each.

$$\text{Content } (\mu\text{g/g}) = \text{sample solution concentration } (\mu\text{g/ml}) \times 20 \text{ (ml)} / \text{sample weight (g)}$$

## Diphenyl Carbonate

### (1) Plotting an analytical curve

Accurately measure 10 mg of diphenyl carbonate and place in a 100 ml measuring flask, and add enough methanol to bring the total volume to 100 ml. In separate 20 ml measuring flasks, place 1 ml, 2 ml, 3 ml, 4 ml, and 5 ml of this solution, then add enough water to bring the total volume to 20 ml. These are the standard solutions (5  $\mu$ g/ml, 10 $\mu$ g/ml, 15  $\mu$ g/ml, 20 $\mu$ g/ml, and 25  $\mu$ g/ml). Using 20  $\mu$ l of each standard solution, perform liquid chromatography according to

the procedure and conditions specified below. Use the resultant liquid chromatogram to calculate the height and area of the peak of diphenyl carbonate, then plot an analytical curve.

**Procedure and conditions**

Column filler	Use octadecylsilyl silica gel.
Column	Use a 250 mm long stainless-steel column with an inner diameter of 4.6 mm.
Column temperature	40°C
Detector	Use an ultraviolet spectrophotometric detector. Operate at a wavelength of 217 nm.
Moving phase	A = acetonitrile; B = water.
Concentration gradient	After conducting a linear concentration gradient from A:B (3:7) to (100:0) for 35 minutes, let the acetonitrile flow for 10 minutes.

**(2) Test**

Using 20 µl of the sample solution, perform liquid chromatography according to the same procedure and conditions as described in (1) Plotting an analytical curve. Use the resultant liquid chromatogram to calculate the height and area of the peak. Next, use the analytical curve to determine the concentration of diphenyl carbonate in the sample solution, then use the following equation to determine the content in the material.

$$\text{Content } (\mu\text{g/g}) = \text{sample solution concentration } (\mu\text{g/ml}) \times 20 \text{ (ml)} / \text{sample weight (g)}$$

**Total lactic acid**

**(1) Qualification test**

Measure 1 ml each of sample solution and lactic acid control solution to the columns, add 100 µl of 0.2 mol/l sodium hydroxide solution to each, plug shut the columns and let them stand at 60 °C for 15 minutes, shaking occasionally to mix them. After the columns have cooled, add 100 µl of 0.2 mol/l phosphoric acid to each column. Using 100 µl of each solution, subject them to liquid chromatography according to the procedure and conditions described below; then, compare the peak detection time for the liquid chromatogram of the sample solution to the peak detection time for the liquid chromatogram of the lactic acid standard solution.

**Procedure and conditions**

Column filler	Use octadecylsilyl silica gel.
Column	Use a 250 mm long stainless-steel column with an inner diameter of 4.6 mm.
Column temperature	40°C.
Detector	Use an ultraviolet spectrophotometric detector. Operate it at a wavelength of 210 nm.
Moving phase	Use a solution of phosphoric acid, acetonitrile and water at 0.1:1:99. Adjust the flow rate such that the lactic acid finishes flowing out in approximately 5 minutes.

**(2) Quantification Test**

Perform the following test if, in the qualification test (1), the peak detection time for the liquid chromatogram of the sample solution matches the peak detection time for the liquid chromatogram of the lactic acid standard solution.

Using the results obtained under the same procedure and conditions as the qualification test (1) as a reference point, measure the peak detection time of the lactic acid in the sample solution. This area should not be greater than the peak detection time of the lactic acid standard solution.

### **Bisphenol A (including phenol and p-tert-butylphenol)**

#### **(1) Plotting an analytical curve**

Accurately measure 10 mg each of bisphenol A, phenol, and p-tert-butylphenol and place in a 100 ml measuring flask, then add enough methanol to bring the total volume to 100 ml. In separate 20 ml measuring flasks, place 1 ml, 2 ml, 3 ml, 4 ml, and 5 ml of this solution, then add enough water to bring the total volume to 20 ml. These are the standard solutions (5 µg/ml, 10 µg/ml, 15 µg/ml, 20 µg/ml, and 25 µg/ml). Using 20 µl of each standard solution, perform liquid chromatography according to the procedure and conditions specified below. Use the resultant liquid chromatogram to calculate the height and area of the peak of bisphenol A, phenol, and p-tert-butylphenol, then plot an analytical curve for each.

When plotting the analytical curve for a leaching test, place 2 ml of each of the aforementioned standard solutions in separate 20 ml measuring flasks and add enough water to bring the total volume to 20 ml. Using 100 µl of each of these solutions (0.5 µg/ml, 1.0 µg/ml, 1.5 µg/ml, 2.0 µg/ml, and 2.5 µg/ml), plot an analytical curves according to the same procedure and conditions.

#### **Procedure and conditions**

Follow the same procedure and conditions as with diphenol carbonate.

#### **(2) Test**

Using 20 µl of the sample solution, perform liquid chromatography according to the same procedure and conditions as described in (1) Plotting an analytical curve. Use the resultant liquid chromatograms to calculate the height and area of each peak. Next, use the analytical lines to determine the concentration of bisphenol A, phenol, and p-tert-butylphenol in the sample solution, then use the following equation to determine the content of each in the material.

$$\text{Content } (\mu\text{g/g}) = \text{sample solution concentration } (\mu\text{g/ml}) \times 20 \text{ (ml)} / \text{sample weight (g)}$$

For a leaching test, use 100 µl of the sample solution and, according to the same procedure and conditions, use the leaching-test analytical curves to determine the concentration of bisphenol A, phenol, and p-tert-butylphenol in the sample solution.

### **Phenol**

Add 20 ml of sample solution with 3 ml of boric acid buffer solution and mix well, then add 5 ml of 4-amino antipyrine and 2.5 ml of potassium hexacyanoferrate (III) and enough water to bring the total volume to 100 ml. Mix well and leave for 10 minutes at room temperature. Also prepare 20 ml of phenol standard solution according to the same procedure. When measured at a wavelength of 510 nm, the spectral absorbance of the sample solution must not exceed that of the phenol standard solution.

## Formaldehyde

Add 10 ml of sample solution with 1 ml of 20% phosphoric acid, then place 5–10 ml of water in a 200 ml measuring cylinder and conduct steam distillation with the cooling unit adapter submerged in water. When the volume of distillate reaches approximately 190 ml, stop distillation and add enough water to bring the total volume to 200 ml. Place 5 ml of this solution in a 15 mm inner-diameter test tube and add 5 ml of acetylacetone reagent. Mix and then heat in a boiling water bath for 10 minutes.

In a separate 15 mm inner-diameter test tube, place 5 ml of water and 5 ml of acetylacetone reagent. Mix and then heat in a boiling water bath for 10 minutes. This is the contrast solution.

When viewed from the side against a white background, the sample solution must not appear darker in color than the contrast solution.

## Methyl Methacrylate

### (1) Qualification Test

Using 1 µl each of sample solution and methyl methacrylate standard solution, perform gas chromatography according to the procedure and conditions described below, then compare the peak detection time in the gas chromatogram of the sample solution to the peak detection time of methyl methacrylate in the gas chromatogram of the methyl methacrylate standard solution.

#### Procedure and conditions

Column	Use a 30 m long silicate-glass column with an inner diameter of 0.32 mm and with a 5 µm thick dimethylpolysiloxane coating.
Column temperature	Heat at 120°C for 1 minute, then raise the temperature at a rate of 5°C per minute until 170°C is reached.
Sample solution inlet temperature	200°C.
Detector	Use a hydrogen flame ionization detector. Operate at or near 200°C. Adjust the flow of air and hydrogen for maximum detection sensitivity.
Carrier gas	Use nitrogen or helium. Adjust the flow rate so that the methyl methacrylate flows out in approximately 4 to 5 minutes.

### (2) Quantification Test

Perform the following test if, in (1) Qualification test, the peak detection time in the gas chromatogram of the sample solution matches the peak detection time of methyl methacrylate in the gas chromatogram of the methyl methacrylate standard solution.

Using the results obtained under the same procedure and conditions as in (1) Qualification test as a reference point, measure the peak area of methyl methacrylate in the sample solution. This area should not be greater than the peak area of the methyl methacrylate standard solution.

## **B-9 Inductively Coupled Plasma Photoemission Spectroscopy**

Inductively coupled plasma photoemission spectroscopy is a technique that uses an inductively coupled plasma (ICP) to atomize and excite the target molecules in a sample and measure the concentration of the target molecule in the sample from an atomic photoemission spectrograph generated.

### **Equipment**

The equipment normally consists of an excitation source, a sample induction unit, a photoemission unit, a spectrometer, a photometer, and a display and recording unit. The excitation source comprises an energy source, a control system and circuits that generate and control the electrical energy to excite the sample and cause optical emission. Accessories include a gas source and cooling unit. The sample induction unit comprises a nebulizer and a mist chamber. Components of the photoemission unit include a torch tube and a high-frequency induction coil. Spectrometer components include a light-condensing unit and a diffraction grating. The photometer consists of a detector and a signal-processing system. The display and recording unit typically includes a display and recording unit. Types of devices include a single-element serial analysis type with a wavelength-scanning spectrometer, a multi-element serial analysis type with a wavelength-scanning spectrometer, and a multi-element simultaneous analysis type with a fixed-wavelength polychromator.

### **Standard solution**

Use the standard solution for the target element, in addition to following any other applicable provisions.

### **Procedure**

After verifying that all electrical components are operating normally, turn on the excitation source and the cooling unit. If using a vacuum spectrometer to measure vacuum ultraviolet photoemission, be sure to sufficiently replace the optical axis between the photoemission unit and the spectrometer with argon or nitrogen. Set the argon or nitrogen to the predetermined flow rate, and turn on the high-frequency power supply to generate the plasma. Use the photoemission of the mercury lamp to calibrate the wavelength of the spectrometer. Next, introduce the sample solution (prepared as separately specified) and measure the photoemission intensity of the appropriate spectral lines.

The photoemission intensity of the sample solution must not exceed that of the standard solution for the target element when analyzed in the same manner.

## **B-10 Preparation of Sample Solutions for Leaching Tests**

Prepare the sample solution according to the following procedure, unless specified otherwise. Rinse the sample thoroughly in water, then use the specified leaching solution to prepare the sample solution as follows.

Use 2 ml of leaching solution for each square centimeter of sample. Heat the solution to 60°C and, maintaining at that temperature, leave for 30 minutes. If the sample is intended for use at temperatures above 100°C and the leaching solution used is 4% acetic acid or heptane, maintain the 4% acetic acid at 95°C for 30 minutes or the heptane at 25°C for 1 hour.

## C Reagents and Solutions

Unless otherwise stipulated, use the reagents, sample solutions, standard volumetric analysis solutions, standard solutions and standard undiluted solutions listed below for testing. In cases other than those indicated below, use those indicated in Part II: Additives, Section C: Reagents and Solutions.

Regarding items marked, for example, [K 8012, For arsenic analysis] or [K 8027, Special]: –K 8012|| and –K 8027|| are JIS numbers, while –For arsenic analysis|| means the reagent, in this case, zinc is used for arsenic analysis, and –Special|| means a special grade of, in this case, zinc.

Items whose names used in this specification differ from their JIS names are noted with the JIS name after the JIS number.

The glass containers in which reagents, sample solutions, standard volumetric analysis solutions, standard solutions and standard undiluted solutions are kept should have very low solubility and alkalinity and as far as possible should not contain lead or arsenic.

### C-1 Reagents

Zinc (for arsenic testing)	Zn	[K 8012, For arsenic analysis]	Granular
Acetylacetone	CH <sub>3</sub> COCH <sub>2</sub> COCH <sub>3</sub>	[K 8027, Special]	
Acetonitrile	CH <sub>3</sub> CN	[K 8032, Special]	
4-Aminoantipyrine	C <sub>11</sub> H <sub>13</sub> N <sub>3</sub> O	[K 8048, Special]	
Ammonia solution	NH <sub>3</sub>	[K 8085, Special]	Contains 28% - 30% ammonia.
Isopropyl benzene			Contains at least 98% isopropyl benzene.
Ethanol (99.5)	C <sub>2</sub> H <sub>5</sub> OH	[K 8101, Special]	
Ethanol (for vinyl chloride testing)			Ethanol (99.5), when testing for vinyl chloride, confirm that no substances that interfere with testing are contained.
Ethyl benzene	C <sub>2</sub> H <sub>5</sub> C <sub>6</sub> H <sub>5</sub>		Contains at least 99% ethyl benzene.

Epichlorohydrin	C <sub>3</sub> H <sub>5</sub> ClO		Contains at least 98% epichlorohydrin.
Antimony (III) chloride	SbCl <sub>3</sub>	[K 8400, Special]	
Tin (II) chloride dehydrate	SnCl <sub>2</sub> · 2H <sub>2</sub> O	[K 8136, Tin (II) chloride dihydrate, Special]	
Vinylidene chloride	C <sub>2</sub> H <sub>2</sub> Cl <sub>2</sub>		Contains at least 99% vinylidene chloride.
Vinyl chloride	C <sub>2</sub> H <sub>3</sub> Cl		Contains at least 99.5% vinyl chloride.
Hydrochloric acid	HCl	[K 8180, Special]	
Hydrochloric acid (for arsenic testing)	HCl	[K 8180, for arsenic analysis]	
Caprolactam	C <sub>6</sub> H <sub>11</sub> NO		Contains at least 98% caprolactam.
Potassium permanganate	KMnO <sub>4</sub>	[K 8247, Special]	
Cadmium	Cd		Contains at least 99.9% cadmium.
Citric acid monohydrate	H <sub>3</sub> C <sub>6</sub> H <sub>5</sub> O <sub>7</sub> · H <sub>2</sub> O	[K 8283, Citric acid monohydrate, Special]	
Diammonium hydrogen citrate	C <sub>5</sub> H <sub>14</sub> N <sub>2</sub> O <sub>7</sub>	[K 8284, Diammonium hydrogen citrate, Special]	
Glycerine	CH <sub>2</sub> (OH)CH(OH)C H <sub>2</sub> OH	[K8295, Special]	
Tricresyl phosphate	(C <sub>6</sub> H <sub>4</sub> CH <sub>3</sub> O) <sub>3</sub> PO		Contains at least 90% tricresyl phosphate.
Acetic acid	CH <sub>3</sub> COOH	[K 8355, Special]	
Ammonium acetate	CH <sub>3</sub> COONH <sub>4</sub>	[K 8359, Special]	
Sodium acetate	CH <sub>3</sub> COONa	[K 8372, Special]	
Lead (II) acetate trihydrate	Pb(CH <sub>3</sub> COO) <sub>2</sub> · 3H <sub>2</sub> O	[K 8374, Special]	
Arsenic trioxide	As <sub>2</sub> O <sub>3</sub>	[K 8044, Arsenic trioxide, Special]	
Potassium cyanide	KCN	[K 8443, Special]	
Silver N,N-diethyldithiocarbamate	C <sub>5</sub> H <sub>10</sub> AgNS <sub>2</sub>	[K 9512, Special]	
Diethylbenzene			Contains at least 98% 1,4-diethylbenzene.
2,6-dichloroquinone chlorimide	C <sub>6</sub> H <sub>2</sub> Cl <sub>2</sub> NO		
Dichloromethane	CH <sub>2</sub> Cl <sub>2</sub>	[K 8161, Special]	
N,N-Dimethyl acetamide	CH <sub>3</sub> CON(CH <sub>3</sub> ) <sub>2</sub>		When testing for vinylidene chloride or vinyl chloride,

			confirm that no substances are contained that interfere with testing.
Diphenyl carbonate	$(C_6H_5)_2CO_3$		Contains at least 97% diphenyl carbonate.
Ammonium oxalate monohydrate	$(NH_4)_2C_2O_4 \cdot H_2O$	[K 8521, Ammonium oxalate monohydrate, Special]	
Sodium oxalate	$NaC_2O_4$	[K 8528, Sodium oxalate, Special]	
Nitric acid	$HNO_3$	[K 8541, Special]	
Lead (II) nitrate	$Pb(NO_3)_2$	[K 8563, Special]	
Barium nitrate	$Ba(NO_3)_2$	[K 8565, Special]	
Sodium hydroxide	$NaOH$	[K 8576, Special]	
Styrene	$C_6H_5CHCH_2$		Contains at least 99% styrene.
Sodium carbonate	$Na_2CO_3$	[K 8625, Special]	
Nitrogen	$N_2$		Use high purity nitrogen.
Sodium tetraethylborate	$(C_2H_5)_4BNa$		Contains at least 98% sodium tetraethylborate.
Tetrahydrofuran	$C_4H_8O$	[K 9705, Special]	When testing for volatile substances, confirm that no substances are contained that interfere with testing.
Triethylamine	$(C_2H_5)_3N$		Contains at least 99% triethylamine.
Tributylamine	$(C_4H_9)_3N$		Contains at least 98% tributylamine.
Toluene	$C_6H_5CH_3$	[K 8680, Special]	
Dibutyltin dichloride	$(C_4H_9)_2SnCl_2$		Contains at least 97% dibutyltin dichloride.
Germanium dioxide	$GeO_2$		Contains at least 99% germanium dioxide.
Lithium L-lactate	$CH_3CH(OH)COOLi$		Contains at least 97% lithium lactate.
Bisphenol A	$(CH_3)_2C(C_6H_4OH)_2$		Contains at least 99% bisphenol A.
Pyridine	$C_5H_5N$	[K 8777, Special]	
Phenol	$C_6H_5OH$	[K 8798, Special]	
p-tert-butylphenol	$(CH_3)_3CC_6H_4OH$		Contains at least 99% p-tert-butylphenol.
Propylbenzene	$C_6H_5C_3H_7$		Contains at least 97% propylbenzene.
Bromophenol blue	$C_{19}H_{10}Br_4O_5S$	[K 8844, Special]	
Hexane	$C_6H_{14}$	[K 8848, Special]	
Potassium	$K_3[Fe(CN)_6]$	[K 8801, Special]	

hexacyanoferrate (III)			
Heptane	C <sub>7</sub> H <sub>16</sub>	[K 9701, Special]	
Pentane	C <sub>5</sub> H <sub>12</sub>		When testing for epichlorohydrin, confirm that no substances that interfere with testing are contained.
Boric acid	H <sub>3</sub> BO <sub>3</sub>	[K 8863, Boric acid, Special]	
Methyl methacrylate	C <sub>3</sub> H <sub>5</sub> COOCH <sub>3</sub>		Contains at least 98% methyl methacrylate.
Methylene blue	C <sub>6</sub> H <sub>18</sub> ClN <sub>3</sub> S•3H <sub>2</sub> O	[K 8897, Special]	
2-Mercaptoimidazoline	C <sub>3</sub> H <sub>6</sub> N <sub>2</sub> S		Contains at least 95% mercaptoimidazoline.
Potassium iodide	KI	[K 8913, Potassium iodide, Special]	
Sodium sulfide nonahydrate	Na <sub>2</sub> S•9H <sub>2</sub> O	[K 8949, Special]	
Sulfuric acid	H <sub>2</sub> SO <sub>4</sub>	[K 8951, Special]	
Phosphoric acid	H <sub>3</sub> PO <sub>4</sub>	[K 9005, Special]	

## C-2 Solutions

When preparing solutions, use reagents listed in C-1: Reagents.

Acetylacetone sample solution	Dissolve 150g of ammonium acetate in water, add 3 ml acetic acid and 2 ml acetylacetone; add more water to bring the total volume to 1,000 ml. Prepare just before use.
4-Aminoantipyrine sample solution	Dissolve 1.36g of 4-aminoantipyrine in water to bring the total volume to 1,000 ml.
Ammonia sample solution	Measure out 400 ml of ammonia solution and add water to bring the total volume to 1,000 ml. 20% ethanol Measure out 40 ml ethanol (99.5) and add water to bring the total volume to 200 ml.
Tin (II) chloride sample solution	Measure out 4 g of tin (II) chloride dihydrate, add 125 ml of hydrochloric acid (for arsenic testing), dissolve and add water to bring the total volume to 250 ml. Put in a stoppered bottle and seal tightly for storing. Use within a month of preparation.
6 mol/l hydrochloric acid	Add water to 540 ml of hydrochloric acid to bring the total volume to 1,000 ml.
1 mol/l hydrochloric acid	Add water to 90 ml of hydrochloric acid to bring the total volume to 1,000 ml.
0.1 mol/l hydrochloric acid	Add water to 100 ml of 1 mol/l hydrochloric acid to bring the total volume to 1,000 ml.
Weak sulfuric acid (for sustained	Gradually add 7.54 g sulfuric acid to 1,000 ml of water.

pressure test)	
0.5% citric acid solution	Measure out 5 g of citric acid monohydrate, add water to bring the total volume to 1,000 ml, and use sodium hydroxide sample solution to adjust pH to 3.5.
Ammonium citrate sample solution	Dissolve 25 g of diammonium hydrogen citrate in water to bring the total volume to 100 ml.
4% acetic acid	Measure out 40 ml of acetic acid and add water to bring the total volume to 1,000 ml.
Acetic acid / sodium acetate buffer solution	Solution No. 1: Measure out 12 g of acetic acid and add water to bring the total volume to 100 ml. Solution No. 2: Dissolve 16.4 g of sodium acetate in water to bring the total volume to 100 ml. Mix three parts solution No. 1 with seven parts solution No. 2.
Lead acetate sample solution	Measure out 11.8 g of lead (II) acetate trihydrate, dissolve in water to bring the total volume to 100 ml, and add two drops acetic acid (1→4). Keep in tightly sealed container.
Potassium cyanide sample solution	Dissolve 1 g of potassium cyanide in 10 ml of water. Prepare just before using.
Diethylbenzene sample solution	Add tetrahydrofuran to 1 ml of diethylbenzene to bring the total volume to 100 ml, take 10 ml of this and add more tetrahydrofuran to bring the total volume to 100 ml.
2,6-dichloroquinone chlorimide ethanol sample solution	Dissolve 100 mg of 2,6-dichloroquinone chlorimide in ethanol to bring the total volume to 10 ml.
Ammonium oxalate sample solution	A saturated solution of ammonium oxalate monohydrate. Dissolve 5 g of ammonium oxalate monohydrate in water to bring the total volume to 100 ml.
0.1 mol/l nitric acid	Add water to 6.4ml of nitric acid to bring the total volume to 1,000 ml.
Sodium hydroxide sample solution	Dissolve 4.3 g of sodium hydroxide in water to bring the total volume to 100 ml.
0.2 mol/l sodium hydroxide sample solution	Dissolve 8.0 g of sodium hydroxide in water to bring the total volume to 1,000 ml.
Sodium tetraethylborate sample solution	Dissolve 1 g of sodium tetraethylborate in water to bring the total volume to 50 ml. Prepare just before using.
Hydrogen arsenide absorbed liquid	Dissolve 0.50 g of silver N, N-diethyldithiocarbamate in pyridine to bring the total volume to 100 ml. Place this liquid in a light-blocking stoppered bottle and store in a cool place.
Bromophenol blue sample solution	Measure out 0.1 g of bromophenol blue, add 100 ml of 50% ethanol, dissolve, and if necessary, filter.
Potassium hexacyanoferrate (III) sample solution	Dissolve 8.6 g of potassium hexacyanoferrate (III) in water, add 1.8 ml of ammonia solution and enough water to bring the total volume to 1,000 ml.
Boric acid buffer solution	Solution No. 1: Dissolve 4.0 g of sodium hydroxide in water to bring the total volume to 100 ml.

	Solution No. 2: Dissolve 6.2 g of boric acid in water to bring the total volume to 100 ml. Measure out equal parts of solution No. 1 and solution No. 2 and mix.
Methylene blue sample solution (for pinhole testing)	Measure out 0.4 g of methylene blue and dissolve in water containing 10 ml of ethanol to bring the total volume to 100 ml.
Potassium iodide sample solution	Measure out 16.5 g of potassium iodide, add water to bring the total volume to 100 ml. Store protected from light.
Sodium sulfide sample solution	Measure out 5g of sodium sulfide nonahydrate, add a mixture of 10 ml water and 30 ml glycerine and dissolve. Place in a small, light-blocking bottle until the bottle is nearly full and seal tightly for storing. Use within three months of preparation.
0.2 mol/l phosphoric acid	Dissolve 14 ml of phosphoric acid in water to bring the total volume to 1,000 ml.

### C-3 Standard volumetric analysis solutions

#### 0.002 mol/l potassium permanganate solution

Dissolve approximately 0.31 g of potassium permanganate in water to bring the total volume to 1,000 ml. Store in a light-blocking stoppered bottle. When needed, use 0.005 mol/l sodium oxalate solution to standardize.

##### Standardization:

Take 100 ml of water, add 5 ml of sulfuric acid (1→3) and 5 ml of potassium permanganate solution and boil for 5 minutes. Next, cut off heat and immediately add 10 ml of 0.005 mol/l sodium oxalate solution. After it loses its color, add potassium permanganate solution by the drop until a slightly red color remains and does not fade. Add 5 ml of sulfuric acid (1→3) and 5 ml of potassium permanganate solution to this liquid and boil for 5 minutes; after this add 10 ml of 0.005 mol/l sodium oxalate solution and immediately titrate with potassium permanganate solution, then determine the factor of the potassium permanganate solution using the following formula.

$$\text{Factor} = 10/(5 + a)$$

Where, a = titration volume (ml) of potassium permanganate solution

#### 0.005 mol/l sodium oxalate solution

Dissolve 0.6700 g of sodium oxalate in water to bring the total volume to 1,000 ml and keep in a light-blocking stoppered bottle. Use within a month of preparation.

## C-4 Standard solutions, standard undiluted solutions

Zinc standard undiluted solution	Measure out 1.0 g of zinc, dissolve in 6 mol/l hydrochloric acid and evaporate and harden on a water bath. Add 1 mol/l hydrochloric acid to the residue to bring the total volume to 1,000 ml. 1 ml of the liquid contains 1 mg of zinc.
Zinc standard solution	Take 1 ml of the zinc standard undiluted solution and add water to bring the total volume to 50 ml. Take 1 ml of this and add a leaching solution (same as the sample solution) to bring the total volume to 20 ml. If using water as the leaching solution, add five drops of acetic acid to this. 1 ml of the liquid contains 1 µg of zinc.
Antimony standard undiluted solution	Measure out 1.874 g of antimony trichloride and dissolve in a small amount of hydrochloric acid (1→2); afterwards add hydrochloric acid (1→10) to bring the total volume to 1,000 ml. 1 ml of the liquid contains 1 mg of antimony.
Antimony standard solution	Take 1 ml of antimony standard undiluted solution, add 4% acetic acid to bring the total volume to 100 ml, take 1 ml of this and add 4% acetic acid to bring the total volume to 200 ml. 1 ml of the liquid contains 0.05 µg of antimony.
Epichlorohydrin standard solution	Dissolve 100 mg of epichlorohydrin in pentane to bring the total volume to 100 ml, take 1 ml of this and add pentane to bring the total volume to 100 ml. Then take 5 ml of this liquid and add pentane to bring the total volume to 100 ml. 1 ml of the liquid contains 0.5 µg of epichlorohydrin.
Vinylidene chloride standard solution	Place approximately 98 ml of N,N-dimethyl acetamide in a 100 ml measuring flask and plug with a silicon rubber stopper. Inject 250 µl of vinylidene chloride into this measuring flask through the silicon rubber stopper. Then inject N,N-dimethyl acetamide through the silicon rubber stopper to bring the total volume to 100 ml. Take 1 ml of this liquid and add N,N-dimethyl acetamide to bring the total volume to 50 ml. 1 ml of this liquid contains 60 µg of vinylidene chloride.
Vinyl chloride standard solution	Place approximately 190 ml of ethanol (for vinyl chloride testing) in a 200 ml measuring flask, plug with a silicon rubber stopper and weigh. Cool the measuring flask in a methanol-dry ice bath and inject 200 mg of already liquefied vinyl chloride through the silicon rubber stopper. Through the silicon rubber stopper, inject the ethanol (for vinyl chloride testing) chilled in the methanol-dry ice bath to bring the total volume to 200 ml. Next, cool this in the methanol-dry ice bath, take 1 ml, and add ethanol (for vinyl chloride testing) chilled in the methanol-dry ice bath to bring the total volume to 100 ml. Store in a methanol-dry ice bath. 1 ml of this liquid contains 10 µg of vinyl chloride.

Cadmium standard undiluted solution	Measure out 100 mg of cadmium, dissolve in 50 ml of 10% nitric acid, evaporate and harden on a water bath, then add 0.1 mol/l nitric acid to the residue to bring the total volume to 100 ml. 1 ml of this liquid contains 1 mg of cadmium.
Cadmium standard solution	Take 1 ml of cadmium standard undiluted solution, add solvent (the same as used to the sample solution) to bring the total volume to 200 ml. However, if using water as the sample solution, add five drops of nitric acid to this. 1 ml of this liquid contains 5 µg of cadmium.
Cadmium standard solution (for testing metal cans)	Take 2 ml of cadmium standard solution, and add a leaching solution to bring the total volume to 100 ml. However, if using water as the leaching solution, add five drops of nitric acid to this. 1 ml of this liquid contains 0.1 µg of cadmium.
Caprolactam standard solution	Measure out 1.5 g of caprolactam and dissolve in 20% ethanol to bring the total volume to 1,000 ml. Take 1 ml of this liquid and add 20% ethanol to bring the total volume to 100 ml. 1 ml of this liquid contains 15 µg of caprolactam.
Lactic acid standard solution	Measure 1.07 g of lithium L-lactate and dissolve it in water to bring the total volume to 1,000 ml. Take 3 ml of this liquid and add water to bring the total volume to 100 ml. 1 ml of this liquid contains 30 µg of lactic acid.
Tricresyl phosphate standard solution	Take 100 mg of tricresyl phosphate, add acetonitrile and dissolve to bring the total volume to 100 ml. Take 1 ml of this and add 60 ml of acetonitrile, then add water to bring the total volume to 100 ml. 1 ml of this liquid contains 10 µg of tricresyl phosphate.
Germanium standard undiluted solution	Measure out 144 mg of germanium dioxide into a platinum crucible, add 1 g sodium carbonate and mix well, then melt by heating, cool and then add water to dissolve. After adding hydrochloric acid and neutralizing the solution, add another 1 ml of hydrochloric acid and then add water to bring the total volume to 100 ml. 1 ml of this liquid contains 1 mg of germanium.
Germanium standard solution	Take 1 ml of germanium standard undiluted solution and add 4% acetic acid to bring the total volume to 100 ml. Take 1 ml of this and add 4% acetic acid to bring the total volume to 100 ml. 1 ml of this liquid contains 0.1 µg of germanium.
Dibutyltin standard solution	Add acetone and two or three drops of hydrochloric acid to 100 mg of dibutyltin dichloride and dissolve, then add acetone to bring the total volume to 100 ml. Take 1 ml of this and add hexane and two or three drops of hydrochloric acid to bring the total volume to 1,000 ml. 1 ml of this liquid contains 1 µg of dibutyltin dichloride.
Lead standard undiluted solution	Dissolve 159.8 mg of lead (II) nitrate in 10 ml of 10% nitric acid and add water to bring the total volume to 100 ml. 1 ml of this solution contains 1 mg of lead.
Lead standard	Take 1 ml of lead standard undiluted solution and use solvent (same as

solution	used to make the sample solution) to bring the total volume to 200 ml. However, if using water as the sample solution, add five drops of nitric acid to this. 1 ml of the liquid contains 5 µg of lead.
Lead standard solution (for testing metal cans)	Take 8 ml of lead standard solution and use solvent (same as used to make the leaching solution) to bring the total volume to 100 ml. However, if using water as the leaching solution, add five drops of nitric acid to this. 1 ml of the liquid contains 0.4 µg of lead.
Lead standard solution (for heavy metal testing)	Take 1 ml of lead standard undiluted solution and add water to bring the total volume to 100 ml. Prepare just before using. 1 ml of the liquid contains 10 µg of lead.
Barium standard undiluted solution	Dissolve 190.3 mg of barium nitrate in 0.1 mol/l nitric acid to bring the total volume to 100 ml. 1 ml of the liquid contains 1 mg of barium.
Barium standard solution	Take 1 ml of barium standard undiluted solution and add 0.1 mol/l nitric acid to bring the total volume to 1,000 ml. 1 ml of this liquid contains 1 µg of barium.
Arsenic standard undiluted solution	Make the arsenic trioxide into a fine powder, dry for four hours at 105°C, measure out 0.10 g, add 5ml of sodium hydroxide solution (1→5) and dissolve. Neutralize this liquid with sulfuric acid (1→20), add 10 ml more of sulfuric acid (1→20), add newly boiled and chilled water to bring the total volume to 1,000 ml. 1 ml of this liquid contains 0.1 mg of arsenic trioxide. Arsenic standard solution Take 10 ml of arsenic standard undiluted solution, add 10 ml of sulfuric acid (1→20), add newly boiled and chilled water to bring the total volume to 1,000 ml. 1 ml of this liquid contains 1 µg of arsenic trioxide. Prepare just before using and store in a stoppered bottle.
Phenol standard solution	Dissolve 1.0 g of phenol in water to bring the total volume to 100 ml, take 1 ml of this and add water to bring the total volume to 100 ml. Then take 1 ml of this liquid and add water to bring the total volume to 20 ml. 1 ml of this liquid contains 5 µg of phenol.
Methyl methacrylate standard solution	Take 1.5 g of methyl methacrylate and dissolve in 20% ethanol to bring the total volume to 1,000 ml. Take 1 ml of this liquid and add 20% ethanol to bring the total volume to 100 ml. 1 ml of this liquid contains 15 µg of methyl methacrylate.
2-Mercaptoimidazolin e standard solution	Take 200 mg of 2-mercaptoimidazoline and dissolve in methanol to bring the total volume to 100 ml. Take 1 ml of this liquid and add methanol to bring the total volume to 100 ml. 1 ml of this liquid contains 20 µg of 2-mercaptoimidazoline.

## **D. Material-specific Specifications for Implements, Containers, and Packaging, and Raw Materials**

### **D-1 Glass, porcelain or enameled implements, containers,**

**and packaging Glass, porcelain or enameled implements, containers, and packaging must conform to standards under the following test method.**

(1) Test sample whose depth is 2.5 cm or deeper when filled with liquid - excluding enameled ones with the capacity of 3 L and over

**a. Preparation of sample solution**

After washing the sample well with water, put 4% acetic acid in it and leave for 24 hours in a dark, room-temperature place. Transfer this liquid to a beaker and use as sample solution.

**b. Elution testing  
Cadmium and lead**

When atomic absorption spectrometry or inductively coupled plasma photoemission spectroscopy is used to test for cadmium and lead using, respectively, cadmium standard solution (for testing glass, etc.) and lead standard solution as the standard solutions, the results must conform to the standards thereof. To conform, cadmium in the sample solution must be no more than 0.5 µg/ml and lead must be no more than 5 µg/ml. In addition, in the case of samples of capacity 1.1l or greater, when the test is performed similarly but 4% acetic acid is added to 50 ml of the cadmium standard solution (for testing glass, etc.) and 50 ml of the lead standard solution as the standard solutions to bring the total volume to 100 ml, the results must conform to the standards thereof. To conform, cadmium in the sample solution must be no more than 0.25 µg/ml and lead must be no more than 2.5 µg/ml.

<1> Plotting an analytical curve

Dilute Cadmium Standard Solution and Lead Standard Solution with 4% acetic acid into appropriate concentrations, determine the concentrations by atomic absorption spectrophotometry or inductively coupled plasma atomic emission spectrometry, and generate respective calibration curves.

<2> Quantitative method

When the concentrations of cadmium and lead leached in the test solution are determined by atomic absorption spectrophotometry or inductively coupled plasma atomic emission spectrometry, the amount leached per unit area shall be equal to or less than the limits given in Columns 2 for cadmium and Column 3 for lead, for corresponding category given in Column 1 of the following table.

Column 1		Column 2	Column 3
Glass equipment and containers	Heat-cooking wave	0.05 µg/ml	0.5 µg/ml
	Those other than heat-cooking ware	Capacity less than 600 ml	0.5 µg/ml
		Capacity 600 ml and over and less than 3 L	0.25 µg/ml

		Capacity 3 L and over	0.25 µg/ml	0.5 µg/ml
Ceramic equipment and containers	Heat-cooking ware		0.05 µg/ml	0.5 µg/ml
	Those other than heat-cooking ware	Capacity less than 1.1 L	0.5 µg/ml	2 µg/ml
		Capacity 1.1 L and over and less than 3 L	0.25 µg/ml	1 µg/ml
		Capacity 3 L and over	0.25 µg/ml	0.5 µg/ml
Enameled equipment and containers	Heat-cooking ware whose capacity is less than 3 L		0.07 µg/ml	0.4 µg/ml
	Those other than heat-cooking ware whose capacity is less than 3 L		0.07 µg/ml	0.8 µg/ml

(2) Test sample that cannot be filled with liquid, or test sample whose depth is less than 2.5 cm when filled with liquid, or enameled test sample with the capacity of 3 L and over.

#### a. Preparation of sample solution

After washing the sample (for enameled products with the capacity of 3 L and over, prepare flat pieces of the test sample and use it as test sample) well with water, use 4% acetic acid as leaching solution and leave for 24 hours in a dark, room-temperature place.

#### b. Elution testing

##### i) Cadmium and lead

##### <1> Plotting an analytical curve

Dilute Cadmium Standard Solution and Lead Standard Solution with 4% acetic acid into appropriate concentrations, determine the concentrations by atomic absorption spectrophotometry or inductively coupled plasma atomic emission spectrometry, and generate respective calibration curves.

##### <2> Quantitative method

Determine the concentration (C µg/ml) of cadmium and lead respectively in the test solution by atomic absorption spectrophotometry or inductively coupled plasma atomic emission spectrometry. Obtain the amount of migration per unit area for each element by the formula given below, in which the surface area of the sample product is expressed as S (cm<sup>2</sup>) and the total volume of the solution used to elute the element as V (ml). The amount leached per unit area shall be equal to or less than the limits given in Column 2 for cadmium and Column 3 for lead, for corresponding category given in Column 1 of the following table.

$$\text{Elution volume per unit surface area } (\mu\text{g}/\text{cm}^2) = (C \times V) / S$$

Column 1			Column 2	Column 3
Glass equipment and containers			0.7 µg/cm <sup>2</sup>	8 µg/cm <sup>2</sup>
Ceramic equipment and containers			0.7 µg/cm <sup>2</sup>	8 µg/cm <sup>2</sup>
Enameled	Those that cannot be filled	Heat-cooking ware	0.5 µg/cm <sup>2</sup>	1 µg/cm <sup>2</sup>

equipment and containers	with liquid, or those whose depth is less than 2.5 cm when filled with liquid	Products other than heat-cooking ware	0.7 µg/cm <sup>2</sup>	8 µg/cm <sup>2</sup>
	Those whose depth is 2.5 cm or deeper when filled with liquid and have the capacity of 3 L or over		0.5 µg/cm <sup>2</sup>	1 µg/cm <sup>2</sup>

## D-2 Synthetic resin implements, containers, and packaging

### (1) General specifications

Synthetic resin implements, containers, and packaging must conform to standards under the following test methods (for synthetic resin products in which phenol resin, melamine resin or urea resin is the main component, this excludes the potassium permanganate consumption test described in ii) of b. Elution testing).

#### a. Materials testing

##### Cadmium and lead

Take 1.0 g of sample in a platinum, quartz or heat-resistant glass evaporating dish, add 2ml of sulfuric acid, gradually heat, and continue heating until white smoke has mostly stopped coming from the sulfuric acid and most of the material has carbonized. Heat this in an electric furnace at approximately 450°C to carbonize. Until it completely carbonizes, repeat the process of moistening the content of the evaporation dish with sulfuric acid and reheating. Add 5ml of hydrochloric acid (1→2) to the residue, mix, and evaporate and harden on a water bath. After cooling, add 20 ml of 0.1 mol/l nitric acid, dissolve, filter away any undissolved matter, and use the liquid as sample solution. When atomic absorption spectrometry or inductively coupled plasma photoemission spectroscopy is used to test for cadmium and lead, the results must conform to the standards thereof. To conform, cadmium and lead in the sample solution must each be no more than 5 µg/ml and each must be no more than 100 µg/g on a per-sample basis.

#### b. Elution testing

##### i) Heavy metals

When performing heavy metals tests on sample solutions made by using 4% acetic acid as leaching solution, the results must conform to the standards thereof. To conform, the amount of heavy metals in the form of lead in the sample solution must be no more than 1 µg/ml.

##### ii) Potassium permanganate consumption

When performing potassium permanganate consumption tests, sample solutions made by using water as leaching solution must demonstrate consumption of no more than 10 µg/ml.

### (2) Individual specifications

**a. Synthetic resin implements, containers and packaging in which phenol resin, melamine resin or urea resin is the main component**

Synthetic resin implements, containers and packaging in which phenol resin, melamine resin or urea resin is the main component must conform to the standards for the following test method.

**i) Elution testing**

<1> Phenol

When performing the phenol test of the monomer testing method on sample solutions made by using water as leaching solution, the results must conform to the standards thereof. To conform, phenol content must be no more than 5 µg/ml.

<2> Formaldehyde

When performing the formaldehyde test of the monomer testing method on sample solutions made by using water as leaching solution, the results must conform to the standards thereof.

<3> Evaporation residue

When performing evaporation residue tests, the amount must be no more than 30 µg/ml.

**b. Synthetic resin implements, containers and packaging in which formaldehyde is a raw material of production (does not include synthetic resin implements, containers and packaging in which phenol resin, melamine resin or urea resin is the main component)**

Synthetic resin implements, containers and packaging in which formaldehyde is a raw material of production (does not include synthetic resin implements, containers and packaging in which phenol resin, melamine resin or urea resin is the main component) must conform to the standards of the following test method.

**i) Elution testing**

<1> Formaldehyde

When performing the formaldehyde test of the monomer testing method on sample solutions made by using water as leaching solution, the results must conform to the standards thereof.

<2> Evaporation residue

When performing evaporation residue tests, the amount must be no more than 30 µg/ml.

### **c. Synthetic resin implements, containers and packaging in which polyvinyl chloride is the main component**

Synthetic resin implements, containers and packaging in which polyvinyl chloride is the main component must conform to the standards for the following test method.

#### **i) Materials testing**

##### **<1> Dibutyltin compounds**

Finely slice or crush a sample, measure out 0.5 g and place in a stoppered flask. Add 20 ml of a 3:7 mixture of acetone and hexane and one drop of hydrochloric acid, seal tightly and leave overnight at approximately 40°C, occasionally shaking to mix. After cooling, filter out this liquid, mix the filtered liquid and wash liquid, and use a vacuum concentrator to concentrate to approximately 1 ml at no more than 40°C. Next, using hexane, transfer to a 25-ml measuring flask and add hexane to make 25.0 ml. When centrifuging the mixture for approximately 10 minutes at 2,500 rpm and performing the dibutyltin compound test of the additives testing method using the supernatant as sample solution, the results must conform to the standards thereof. To conform, the amount of dibutyltin compound in the sample solution must be no more than 1 µg/ml in the form of dibutyltindichloride and no more than 50 µg/g on a per-sample basis.

##### **<2> Tricresyl phosphate**

Finely slice or crush a sample, measure out 0.5 g and place in a stoppered flask. Add 15ml acetonitrile, seal tightly and leave overnight at about 40°C. Afterwards, filter this liquid, mix the filtered liquid with the wash liquid, add acetonitrile to make 25 ml and use this as the acetonitrile extract. Mix 5 ml of acetonitrile extract with 5 ml of water and inject into octadecyl silylate silica gel minicolumn into which 5 ml of acetonitrile and 5ml of a 1:1 acetonitrile and water mixture have each been previously injected. Afterwards, elute in a 2:1 mixture of acetonitrile and water and take 10 ml of the elution. When performing the tricresyl phosphate test of the additives testing method using this as sample solution the results must conform to the standards thereof. To conform, the amount of tricresyl phosphate in the sample solution must be no more than 10 µg/ml and no more than 1 mg/g on a per-sample basis.

##### **<3> Vinyl chloride**

Finely slice a sample, measure out 0.5 g and place in a 20 ml glass bottle with a septum cap. Next, add 2.5 ml of N,N-dimethyl acetamide and immediately seal. When performing the vinyl chloride test of the monomer testing method using this as sample solution, the results must conform to the standards thereof. To conform, the amount of vinyl chloride must be no more than 1 µg/g. However, for samples that do not dissolve easily, after sealing, shake to mix occasionally at room temperature, leave overnight and use this as the sample solution.

**ii) Elution testing**

**Evaporation residue**

When performing evaporation residue tests, the amount must be no more than 30 µg/ml. However, if using heptane as the leaching solution, the amount must be no more than 150 µg/ml.

**d. Synthetic resin implements, containers and packaging in which polyethylene or polypropylene is the main component**

Synthetic resin implements, containers and packaging in which polyethylene or polypropylene is the main component must conform to the standards for the following test method.

**i) Elution testing**

**Evaporation residue**

When performing evaporation residue tests, the amount must be no more than 30 µg/ml. However, if the sample is to be used at a temperature of no more than 100°C and heptane is used as the leaching solution, the amount must be no more than 150 µg/ml.

**e. Synthetic resin implements, containers and packaging in which polystyrene is the main component**

Synthetic resin implements, containers and packaging in which polystyrene is the main component must conform to the standards for the following test method.

**i) Materials testing**

**Volatile substances**

Measure out 0.5 g of sample precisely, place in a 20 ml measuring flask and add an appropriate amount of tetrahydrofuran. After the sample has dissolved, add 1 ml of diethylbenzene sample solution, and then add tetrahydrofuran to make 20 ml. When performing the volatile substances test of the monomer testing method using this as the sample solution, the total amount of styrene, toluene, ethyl benzene, isopropyl benzene and propylbenzene must be no more than 5 mg/g. However, for expanded polystyrene (only when boiling water is used), the total concentration of each component must be no more than 2mg/g and the concentration of styrene and ethyl benzene must each be no more than 1 mg/g.

**ii) Elution testing**

**Evaporation residue**

When performing evaporation residue tests, the amount must be no more than 30 µg/ml. However, if using heptane as the leaching solution, the amount must be no more than 240 µg/ml.

**f. Synthetic resin implements, containers and packaging in which polyvinylidene chloride is the main component**

Synthetic resin implements, containers and packaging in which polyvinylidene chloride is the main component must conform to the standards for the following test method.

### **i) Materials testing**

#### **<1> Barium**

Measure out 0.5 g of sample into a platinum, quartz or heat-resistant glass evaporation dish; gradually carbonize directly over a flame at approximately 300°C, then heat at approximately 450°C to turn to ash. Add 50 ml of 0.1 mol/l nitric acid to the residue and dissolve. When performing the barium test using this as the sample solution with atomic absorption spectrometry or inductively coupled plasma photoemission spectroscopy, the results must conform to the standards thereof. To conform, the amount of barium in the sample solution must be no more than 1 µg/ml and no more than 100 µg/g on a per-sample basis.

#### **<2> Vinylidene chloride**

Finely slice a sample, measure out 0.5 g and place in a 20 ml glass bottle with a septum cap. Next, add 2.5 ml of N,N-dimethyl acetamide and immediately seal. When performing the vinylidene chloride test of the monomer testing method using this as the sample solution, the results must conform to the standard thereof. To conform, the amount of vinylidene chloride in the sample must be no more than 6 µg/g.

### **ii) Elution testing**

#### **Evaporation residue**

When performing evaporation residue tests, the amount must be no more than 30 µg/ml.

### **g. Synthetic resin implements, containers and packaging in which polyethylene terephthalate is the main component**

Synthetic resin implements, containers and packaging in which polyethylene terephthalate is the main component must conform to the standards for the following test method.

### **i) Elution testing**

#### **<1> Antimony**

When performing the antimony test with atomic absorption spectrometry or inductively coupled plasma luminous intensity measurement on sample solutions made by using 4% acetic acid as leaching solution, the results must conform to the standards thereof. To conform, the amount of antimony in the sample solution must be no more than 0.05 µg/ml.

#### **<2> Germanium**

When performing the germanium test with atomic absorption spectrometry or inductively coupled plasma luminous intensity measurement on sample solutions made by using 4% acetic acid as leaching solution, the results must conform to the standards thereof. To conform, the amount of germanium in the sample solution must be no more than 0.1 µg/ml.

#### **<3> Evaporation residue**

When performing evaporation residue tests, the amount must be no more than 30 µg/ml.

**h. Synthetic resin implements, containers and packaging in which polymethyl methacrylate is the main component**

Synthetic resin implements, containers and packaging in which polymethyl methacrylate is the main component must conform to the standards for the following test method.

**i) Elution testing**

<1> Methyl methacrylate

When performing the methyl methacrylate test of the monomer testing method on sample solution made using 20% ethanol as leaching solution, the results must conform to the standards thereof. To conform, the amount of methyl methacrylate in the sample solution must be no more than 15 µg/ml.

<2> Evaporation residue

When performing evaporation residue tests, the amount must be no more than 30 µg/ml.

**i. Synthetic resin implements, containers and packaging in which nylon is the main component**

Synthetic resin implements, containers and packaging in which nylon is the main component must conform to the standards for the following test method.

**i) Elution testing**

<1> Caprolactam

When performing the caprolactam test of the monomer testing method on sample solution made using 20% ethanol as leaching solution, the results must conform to the standard thereof. To conform, the amount of caprolactam in the sample solution must be no more than 15 µg/ml.

<2> Evaporation residue

When performing evaporation residue tests, the amount must be no more than 30 µg/ml.

**j. Synthetic resin implements, containers and packaging in which polymethyl pentene is the main component**

Synthetic resin implements, containers and packaging in which polymethyl pentene is the main component must conform to the standards for the following test method.

**i) Elution testing**

**Evaporation residue**

When performing evaporation residue tests, the amount must be no more than 30 µg/ml. However, if using heptane as the leaching solution, the amount must be no more than 120 µg/ml.

## **k. Synthetic resin implements, containers and packaging in which polycarbonate is the main component**

### **i) Materials testing**

#### **<1> Bisphenol A (including phenol and p-tert-butylphenol)**

Place 1.0 g of sample in a 200 ml Erlenmeyer flask and add 20 ml of dichloromethane. After the sample has dissolved, add 100 ml of acetone by droplets while mixing well, centrifuge the mixture for approximately 10 minutes at 3,000 rpm and use a vacuum concentrator to concentrate the supernatant to approximately 2 ml. Next, add 10 ml of acetonitrile, and then add water to make 20 ml. Take 1 ml of this and filter through a membrane filter with pores of no more than 0.5  $\mu\text{m}$ . When performing the bisphenol A (including phenol and p-tert-butylphenol) test of the monomer testing method using this as the sample solution, the total amount of bisphenol A, phenol and p-tert-butylphenol must be no more than 500  $\mu\text{g/g}$ .

#### **<2> Diphenyl carbonate**

When performing the diphenyl carbonate test of the monomer testing method using a sample solution derived by an operation like that in the case of (1) Bisphenol A (including phenol and p-tert-butylphenol), the amount must be no more than 500  $\mu\text{g/g}$ .

#### **<3> Amines**

Place 1.0 g of sample in a 200 ml Erlenmeyer flask and add 20 ml of dichloromethane. After the sample has dissolved, add 100 ml of acetone by droplets while mixing well and centrifuge the mixture for approximately 10 minutes at 3,000rpm. Use a vacuum concentrator to concentrate the supernatant to approximately 1 ml, and then add dichloromethane to make 2 ml. When performing the amine (only applies to triethylamine and tributylamine) test of the additives testing method using this as the sample solution, the total amount of triethylamine and tributylamine must be no more than 1  $\mu\text{g/g}$ .

### **ii) Elution testing**

#### **<1> Bisphenol A (including phenol and p-tert-butylphenol)**

##### **<a> Implements, containers and packaging used with oils and fats and fatty food products**

After washing the sample well with water, use heptane as a leaching solution at the ratio of 2 ml per  $\text{cm}^2$  of sample surface area and then leave for one hour at 25°C. Transfer 25 ml of this liquid to a separating funnel, add 10 ml of acetonitrile, shake hard to mix for five minutes, let stand and then transfer the acetonitrile layer to a 25 ml measuring flask. Add 10 ml of acetonitrile to the heptane layer, perform the same operation as above, and add the acetonitrile layer to the measuring flask above. Next, add

acetonitrile to make 25 ml. When performing the bisphenol A (including phenol and p-tert-butylphenol) test of the monomer testing method using this as the sample solution, the total amount of bisphenol A, phenol and p-tert-butylphenol must be no more than 2.5 µg/ml.

<b> Implements, containers and packaging used with food products other than oils and fats and fatty food products

In the case of food product implements, containers and packaging listed in Column 1 of the following table, in the sample solution made using the corresponding solvents listed in Column 2 as leaching solution, when performing the bisphenol A (including phenol and p-tert-butylphenol) test of the monomer testing method, the total amount of bisphenol A, phenol and p-tert-butylphenol must be no more than 2.5 µg/ml.

Table

Column 1	Column 2
Liquor	20% ethanol
Food products other than oils and fats, fatty food products and liquors	
Products of pH higher than 5	Water
Products of pH5 or lower	4% acetic acid

<2> Evaporation residue

When performing evaporation residue tests, the amount must be no more than 30 µg/ml.

**l. Synthetic resin implements, containers and packaging in which polyvinyl alcohol is the main component**

Synthetic resin implements, containers and packaging in which polyvinyl alcohol is the main component must conform to the standards for the following test method.

**a Elution testing**

i) Evaporation residue

When performing evaporation residue tests, the amount must be no more than 30 µg/ml.

**m. Synthetic resin implements, containers and packaging whose main component is polylactic acid**

Synthetic resin implements, containers and packaging whose main component is polylactic acid must pass the following test.

**a. Elution testing**

i) Total lactic acid

Sample solutions made by using water as a leaching solution must pass the total lactic acid test using the monomer testing method. The total lactic acid in the sample solution must not exceed 30 µg/ml.

ii) Evaporation residue

The evaporation residue (µg) from the solution (ml) found by the evaporation residue test must not exceed 30 µg/ml.

### **D-3: Rubber implements, containers and packaging**

(1) Rubber implements (except baby bottles), containers and packaging

Rubber implements (except baby bottles), containers and packaging must conform to the standards for the following test method (in the case of rubber goods that do not contain chlorine, does not include 2-mercaptoimidazoline testing as indicated in ii) of a. Materials testing.

**a. Materials testing**

**i) Cadmium and lead**

Take 1.0 g of sample in a platinum, quartz or heat-resistant glass evaporating dish, add 2ml of sulfuric acid, gradually heat, and continue heating until white smoke has mostly stopped coming from the sulfuric acid and most of the material has carbonized. Heat this to approximately 450°C in an electric furnace to carbonize. Until it completely carbonizes, repeat the process of moistening the content of the evaporation dish with sulfuric acid and reheating. Add 5 ml of hydrochloric acid (1→2) to the residue, mix, and evaporate and harden on a water bath. After cooling, add 20 ml of 0.1 mol/l nitric acid, dissolve, filter away any undissolved matter, and use the liquid as sample solution. When performing the cadmium and lead test with atomic absorption spectrometry or inductively coupled plasma luminous intensity measurement on the sample solution, the results must conform to the standards thereof. To conform, cadmium and lead in the sample solution must each be no more than 5 µg/ml and each must be no more than 100 µg/g on a per-sample basis.

**ii) 2-Mercaptoimidazoline**

Place 1.0 g of sample in cylindrical filter paper and use a Soxhlet extractor and extract for eight hours with approximately 45 ml methanol. Condense this extract to approximately 1 ml, and use 10 µl of this as the sample solution. When performing thin layer chromatography, using 2-mercaptoimidazoline standard solution as the contrast solution and using each of a 5:1 mixture of acetic ether and benzene and a 30:2:1:1 mixture of acetic ether, methanol, ammonia solution and water as developing solvent, a spot corresponding to the brown spot derived from the contrast solution must not be found. With a thin layer plate as the carrier, use thin layer chromatography silica gel

and dry for one hour at 120°C. Using this, when the leading end of the developing solvent has reached a height approximately 10 cm above the base line, stop developing and allow to air-dry. Then, atomize 2,6-dichloroquinone chlorimide ethanol sample solution, heat for 10 minutes at 120°C and observe.

## **b. Elution testing**

### **i) Phenol**

When performing the phenol test of the monomer testing method on sample solutions made by using water as leaching solution, the results must conform to the standards thereof. To conform, phenol in the sample solution must be no more than 5 µg/ml.

### **ii) Formaldehyde**

When performing the formaldehyde test of the monomer testing method on sample solutions made by using water as leaching solution, the results must conform to the standards thereof.

### **iii) Zinc**

Take 1 ml of sample solution made by using 4% acetic acid as leaching solution and add 4% acetic acid to bring the total volume to 15 ml. When performing the zinc test with atomic absorption spectrometry or inductively coupled plasma photoemission spectroscopy on the sample solution, the results must conform to the standards thereof. To conform, the amount of zinc in the solution must be no more than 15 µg/ml.

### **iv) Heavy metals**

When performing the heavy metals test on sample solutions made by using 4% acetic acid as leaching solution, the results must conform to the standards thereof. To conform, the amount of heavy metals in the solution must be no more than 1 µg/ml. However, if a white turbidity affects the test when sodium sulfide sample solution is added, neutralize the sample solution with ammonia solution and make it pH7 or higher, then add potassium cyanide sample solution and perform the test on this.

### **v) Evaporation residue**

When performing evaporation residue tests, the amount must be no more than 60 µg/ml. With implements, use water as leaching solution, and with containers, and packaging for oils and fats and fatty foods, use 20% ethanol as leaching solution.

## **(2) Rubber baby bottles**

Rubber baby bottles must conform to the test standards for the following test method.

### **a. Materials testing**

#### **Cadmium and lead**

When performing testing following i) Cadmium and lead of a. Materials testing of (1) Rubber implements (except baby bottles), containers and packaging, the results must conform to the standards thereof. However, for the standard solutions, add 0.1 mol/l nitric acid to 10 ml of

cadmium standard solution and to 10 ml of lead standard solution to bring the total volume to 100 ml each. To conform, the amount of cadmium and lead in the solution must each be no more than 0.5 µg/ml and each must be no more than 10 µg/g on a per-sample basis.

## **b. Elution testing**

### **i) Preparation of sample solution**

After washing the sample well with water, use the designated leaching solution at a ratio of 20 ml per 1 g of sample weight, leave for 24 hours at 40°C, and use as sample solution.

### **ii) Testing**

#### **<1> Phenol**

Apply i) Phenol of b. Elution testing of (1) Rubber implements (except baby bottles), containers and packaging.

#### **<2> Formaldehyde**

Apply ii) Formaldehyde of b. Elution testing of (1) Rubber implements (except baby bottles), containers and packaging.

#### **<3> Zinc**

Take 20 ml of sample solution made by using water as leaching solution and add five droplets of acetic acid. When performing the zinc test with atomic absorption spectrometry or inductively coupled plasma photoemission spectroscopy on the sample solution, the results must conform to the standards thereof. To conform the amount of zinc in the solution must be no more than 1 µg/ml.

#### **<4> Heavy metals**

Apply iv) Heavy metals of b. Elution testing of (1) Rubber implements (except baby bottles), containers and packaging.

#### **<5> Evaporation residue**

When performing evaporation residue tests, the amount must be no more than 40 µg/ml. Use water as leaching solution.

## **D-4: Metal cans (not include goods with dried food products as content (except oils and fats and fatty foods))**

Metal cans must conform to the standards of the following test methods (however, metal cans that are not coated with synthetic resin in the places in direct contact with food products are not applied for items b. - f. of (2) Testing.)

### **(1) Preparation of sample solution**

Unless prescribed otherwise, prepare the sample solution by the following procedures.

Wash the sample well with water and use the leaching solution stipulated for each testing method to perform the following operation.

For samples in which liquid can be put, put in leaching solution that has been heated to 60°C, cover with a watch glass, and leave for 30 minutes at 60°C.

For samples in which liquid cannot be put, heat an amount of leaching solution equivalent to 2 ml per cm<sup>2</sup> of surface area to 60°C, soak the sample in it and leave at 60°C for 30 minutes.

However, with samples that are used at temperatures greater than 100°C, when using water as leaching solution leave for 30 minutes at 95°C, and when using heptane or pentane as leaching solution leave for one hour at 25°C.

### **(2) Testing**

#### **a. Arsenic, cadmium and lead**

In the case of food product containers, and packaging listed in Column 1 of the following table, perform the following test on sample solution made using the corresponding solvents listed in Column 2 as leaching solution.

<b>Column 1</b>	<b>Column 2</b>
Food products of pH higher than 5	Water
Products of pH5 or lower	0.5% citric acid solution

#### **i) Arsenic**

When performing the arsenic test using 10 ml of sample solution, the results must conform the standards thereof. To conform, the amount of arsenic in the form of arsenic trioxide in the solution must be no more than 0.2 µg/ml.

#### **ii) Cadmium and lead**

When performing the cadmium and lead test using sample solution with atomic absorption spectrometry or inductively coupled plasma photoemission spectroscopy, the results must conform to the standards thereof. However, for sample solution made using water, add five droplets of nitric acid and use. Also, use cadmium standard solution (for testing metal cans) as the cadmium standard solution and lead standard solution (for testing metal cans) as the lead standard solution. To conform, the amount of cadmium and lead in the sample solution must be no more than 0.1 µg/ml and 0.4

µg/ml respectively.

#### **b. Phenol**

When performing the phenol test of the monomer testing method on the sample solutions made by using water as leaching solution, the results must conform to the standards thereof. To conform, the amount of phenol in the solution must be no more than 5 µg/ml.

#### **c. Formaldehyde**

When performing the formaldehyde test of the monomer testing method on the sample solutions made by using water as leaching solution, the results must conform to the standards thereof.

#### **d. Evaporation residue**

When performing evaporation residue testing, the sample solutions prepared using leaching solutions prescribed for evaporation residue testing must have an amount of no more than 30 µg/ml.

However, in cases where the sample is a can that has been coated on the inside with a coating whose main raw material is natural oils or fats and the content of zinc oxide in the coating is greater than 3%, and in cases where heptane is used as leaching solution, the amount of evaporation residue must be no more than 90 µg/ml. Additionally, in these cases, if the amount of evaporation residue is more than 30 µg/ml when using water as leaching solution, the results must conform to the following testing standards.

Add 30 ml of chloroform to the evaporation residue derived using water as leaching solution, heat, filter and then weigh the filtered liquid in a platinum, quartz or heat-resistant glass evaporation dish whose weight is already known. Further, wash the evaporation residue two times, using 10 ml of chloroform each time, then heat, filter, put the filtered liquid together in the evaporation dish, then evaporate and harden on a water bath. After cooling, weigh the substance, find the difference a (mg) in the weight of the evaporation dish before and after and use the following formula to determine the amount of chloroform solubles, which must be no more than 30 µg/ml.

Amount of chloroform solubles (µg/ml) =  $[(a - b) \times 1,000] / \text{amount of sample solution originally taken (ml)}$

Where, b = blank value (mg) for leaching solution of the same volume as sample solution

#### **e. Epichlorohydrin**

When performing the epichlorohydrin test of the monomer testing method on the sample solution made by using pentane as leaching solution, the results must conform to the standards thereof. To conform, the amount of epichlorohydrin in the solution must be no more than 0.5 µg/ml.

#### **f. Vinyl chloride**

For samples in which liquid can be put, put in ethanol cooled to 5°C or below, seal and leave for 24 hours at 5°C or below.

For samples in which liquid cannot be put, use ethanol cooled to 5°C or below in a ratio of 2 ml

per cm<sup>2</sup> of surface area and keep the sample in a sealed container for 24 hours at 5°C or below. Place 10 ml of the derived solution in a glass bottle with a septum cap and immediately seal. When performing the vinyl chloride test of the monomer testing method using this as sample solution, the results must conform to the standards thereof. To conform, the amount of vinyl chloride in the solution must be no more than 0.05 µg/ml.

## **E. Application-specific Specifications for Implements, Containers, and Packaging**

### **E-1**

Containers and packaging of food products packed in containers or packaging and sterilized by pressure / heat (excluding canned and bottled food products.)

Containers and packaging of food products packed in containers or packaging and sterilized by pressure / heat must meet all conditions below (excludes conditions of item (4) in the case of containers and packaging sealed by seaming).

- (1) Must be light-blocking and impermeable to gas. However, this restriction does not apply in cases where there is no risk of loss of content quality as a result of degradation of oils and fats.
- (2) There is no damage, deforming, color staining, discoloration, etc. when the container is filled with water, sealed and subjected to the same pressurization and heating conditions as in the production process.
- (3) There must be no leaks of content or water when performing compression-proof testing of strength and other tests.
- (4) The measured value must be at least 23N when performing heat-sealing strength testing of strength and other tests. However, this restriction does not apply to box-shaped containers or packaging whose maximum pressure at rupture is 20 kPa or higher as determined by the internal pressure-resistance test, which is a strength test.
- (5) There must be no leaks of content or water when performing dropping testing of strength and other tests. However, in cases where containers or packaging are further packed for retail sale, the test shall be performed on containers or packaging in the state they are packed for retail sale.

### **E-2**

Containers and packaging of soft drinks (excludes juice used as raw material.)

Soft drink containers and packaging that are glass containers and packaging, metal

containers and packaging (including those using materials other than metal for sealing purposes at the opening of the container or packaging; the same applies below in this category), synthetic resin containers and packaging, paper containers and packaging processed with synthetic resin, aluminum foil containers and packaging processed with synthetic resin, or containers and packaging of a combination of materials (i.e. have two or more of these: metal, synthetic resin, paper processed with synthetic resin, aluminum foil processed with synthetic resin; the same applies below in this category) must fulfill all the conditions (1) – (4) below.

## (1) Glass containers and packaging

**a. Containers and packaging that are to be recovered and reused shall be transparent.**

**b. Containers and packaging must conform to the standards for the following testing method. However, this restriction does not apply to items capped with paper lids.**

- i) Containers and packaging that are for filling with carbonated soft drinks must not have any gas leakage when performing sustained pressure resistance testing of strength and other tests.
- ii) Containers and packaging that are for heated filling with soft drinks must not have any air leakage when performing decompression resistance testing of strength and other tests.
- iii) Containers and packaging that are for filling with non-carbonated soft drinks and which are to be filled with techniques other than heated filling must not have any content leakage when performing liquid leakage testing of strength and other tests.

## (2) Metal containers and packaging

**a. Containers and packaging must conform to the standards for the following testing method.**

- i) Containers and packaging whose internal pressure will exceed atmospheric pressure at ordinary temperatures must not have any air leakage when performing pressure resistance testing of strength and other tests.
- ii) Containers and packaging whose internal pressure will be the same as or less than atmospheric pressure at ordinary temperatures must not have any air leakage when performing decompression resistance testing of strength and other tests.

**b. Containers and packaging using materials other than metal for sealing purposes at the opening of the container or packaging must conform to the standards for the following testing methods.**

- i) Pinholes must not be found when performing pinhole testing of strength and other tests. The opening must be turned to the bottom during testing.

- ii) Materials other than metal used for sealing purposes must have a measured value of at least 490 kPa when performing bursting strength testing of strength and other tests.
  - iii) Materials other than metal used for sealing purposes must have a measured value of at least 15N when performing piercing strength testing of strength and other tests.
- (3) Synthetic resin containers and packaging, paper containers and packaging processed with synthetic resin, aluminum foil containers and packaging processed with synthetic resin a. Synthetic resin that is used in places that come in direct contact with the content shall be as prescribed in the individual specifications listed in Part III: Implements, Containers, and Packaging, Section D: Material-specific Specifications for Implements, Containers, and Packaging, and Raw Materials, Paragraph 2: Synthetic Resin Implements, Containers and Packaging, Sub-paragraph (2): Individual Specifications. However, this restriction does not apply to items used for sealing purposes and using aluminum foil processed with synthetic resin.

**b. Containers and packaging must conform to the standards for the following testing method.**

- i) There must be no leaks of content or water when performing dropping testing of strength and other tests.
- ii) Pinholes must not be found when performing pinhole testing of strength and other tests.
- iii) Paper containers and packaging processed with synthetic resin and sealed by heat-sealing must not have any air leakage when performing sealing testing of strength and other tests.
- iv) Synthetic resin containers and packaging and aluminum foil containers and packaging processed with synthetic resin and sealed by heat-sealing must not have any leaks of content or water when performing compression-proof testing of strength and other tests.
- v) Containers and packaging that are for filling with carbonated soft drinks and sealed with a cap, etc. must not have any gas leakage when performing sustained pressure testing of strength and other tests.
- vi) Containers and packaging that are for heated filling with soft drinks and sealed with a cap, etc. must not have any methylene blue staining when performing sustained decompression testing of strength and other tests.

- vii) Containers and packaging that are for filling with non-carbonated soft drinks and which are to be filled with techniques other than heated filling and sealed with a cap, etc. must not have any content leakage when performing liquid leakage testing of strength and other tests.

(4) Containers and packaging of a combination of materials

**a. Metal must conform to the specifications listed in Part III: Implements, Containers, and Packaging, Section D: Material-specific Specifications for Implements, Containers, and Packaging and Raw Materials, Paragraph 4.: Metal Cans (Does not include goods with dried food products as content (except oils and fats and fatty foods); the same applies below for this category.); synthetic resins, paper processed with synthetic resin and aluminum foil processed with synthetic resin must conform to the specifications listed in a. of (3) Synthetic resin containers and packaging, paper containers and packaging processed with synthetic resin, aluminum foil containers and packaging processed with synthetic resin.**

**b. Containers and packaging must conform to the standards for the following testing method.**

- i) There must be no leaks of content or water when performing dropping testing of strength and other tests.
- ii) Pinholes must not be found when performing pinhole testing of strength and other tests.
- iii) Containers and packaging sealed by heat-sealing must not have any air leakage when performing sealing testing of strength and other tests.
- iv) Containers and packaging that are for heated filling with soft drinks must not have any air leakage after decompression testing of strength and other tests.
- v) Containers and packaging that are for filling with soft drinks and which are to be filled with techniques other than heated filling and sealed with techniques other than heat-sealing must not have any content leakage when performing liquid leakage testing of strength and other tests.

### **E-3**

Implements used in production of frozen confections

- (1) Implements used in the production of frozen confections must have a structure that is easy to wash, must be smooth on the interior surface and any surface in contact with food, and must either be made of a rust-proof material or be treated to prevent rust.
- (2) Frozen confection dispensers and cappers must be easy to wash and sterilize and designed to prevent contamination.

- (3) Containers used to keep and transport frozen confections must have means to keep out dust and insects and must have a structure that keeps melted liquid from having direct contact with frozen confections.

## **E-4**

Food product vending machines (only includes those with a structure that allows food to come into direct contact with components) and containers used to sell food products with these must conform to all the conditions of (1) to (3) below.

### **(1) Vending machines (machine proper)**

#### **a. Materials**

The materials used to make components with which food products have direct contact shall be made of materials such as stainless steel that have no risk of elution of toxic or harmful substances and that are resistant to acid, heat and water and are non-permeable. However, non-permeable materials are not necessary for items used to filter food products.

#### **b. Structure and function**

- i) Components that have direct contact with food products must be easy to wash and sterilize.
- ii) Food products or components that have direct contact with them must not be easy to touch from the outside of the machine.
- iii) To protect components where food products are kept from the heat of other, heat-generating components, vending machines must either have ventilation equipment or a partition between components where food products are kept and other components.
- iv) Components that keep or prepare food products must be designed to prevent contamination, by keeping out mice, insects, dust, etc.
- v) The part where the food product comes out must be designed to prevent contact with the outside except during the sale.
- vi) Components used to keep food implements (chopsticks, cups, etc.) and seasonings must be designed to prevent contamination by dust, etc. However, this restriction does not apply in cases where such items are placed or wrapped in containers, packaging or wrappers that prevent contamination with dust, etc.
- vii) Doors to compartments in which food products are kept must be lockable.
- viii) Vending machines that prepare the food products must do so automatically at the

time of each sale. However, vending machines that brew coffee do not need to brew the coffee at the time of each sale if they meet the following conditions i). through iv).

<a> Coffee vending machines must be designed to automatically stop selling if the temperature of the water at the time of coffee brewing is less than 85°C .

<b> Coffee vending machines must have heating equipment capable of maintaining brewed coffee at a temperature of at least 63°C and be designed to automatically stop selling and prevent automatic resumption of sales if that temperature is not kept.

<c> Coffee vending machines must be designed to automatically stop selling if the brewed coffee has been kept more than 22 hours.

<d> Coffee vending machines must have equipment to keep components that keep the brewed coffee (only applies to components in direct contact with the coffee) at a temperature of at least 63°C and to dry them for at least two hours once a day.

ix) For vending machines that prepare food with hot water, the temperature of the water supplied at the time of each sale must be at least 85°C, and the machine must be designed to automatically stop selling if the temperature of the water is less than 85°C. However, this restriction does not apply to vending machines that prepare soft drinks from powder and have containers already filled with food preparation material that fulfill the conditions of both <a> and <b> below and the preparation takes place in those containers, where the temperature of the water supplied at the time of each sale is at least 75°C, and the machine is designed to automatically stop selling if the temperature of the water is less than 75°C.

<a> The material is a powder or finely sliced material and has been dried.

<b> The number of live bacilli must be no more than 3,000 per 1 g, and the sample must test negative for coliform bacilli. In this case, the live bacilli measurement method and coliform bacilli testing method shall follow Part I: Foodstuffs, Section C: Specific Food Items, Sub-section C2: Powdered Drink Beverages, Paragraph 1: Standards for Powdered Drink Beverage Components, Sub-paragraph (3)-a., b. and c.

x) Vending machines that freeze or refrigerate food products or keep them warm (does not include carbonated soft drinks or food products that have been packed in containers or packaging and have been sterilized by pressure / temperature) must have automatic temperature adjustment equipment capable of adjusting the food products' storage temperature and a thermometer showing the products' storage temperature. However, this restriction does not apply to soft drink vending

machines that sell by the cup that have a structure of pipes and other components that is completely closed and moreover use transportation implements that are plugged shut, sealed or protected by measures equivalent to these.

- xi) Vending machines that freeze or refrigerate food products or keep them warm (does not include carbonated soft drinks or food products that have been packed in containers or packaging and have been sterilized by pressure / temperature) must have chilling or heating equipment capable of maintaining food products at the following temperature and be designed to automatically stop selling and prevent automatic resumption of sales if that temperature is not kept. However, this restriction does not apply to soft drink vending machines that sell by the cup that have a structure of pipes and other components that is completely closed and moreover use transportation implements that are plugged shut, sealed or protected by measures equivalent to these.

<a> For vending machines that freeze food products, no more than -15°C

<b> For vending machines that refrigerate food products, no more than 10°C

<c> For vending machines that keep food products warm, no less than 63°C

- xii) Vending machines that use water from a water system based on the Water Supply Law must be capable of automatically injecting water from the water tap and must be designed to prevent backflow into the water system. However, this restriction does not apply to vending machines that get their water from cartridge water tanks (i.e. containers that are placed in vending machines in order to supply water to them, and which are subsequently removed; the same applies below in this category).
- xiii) Vending machines that use water from cartridge water tanks or water other than that supplied by a water system based on the Water Supply Law shall have water sterilization equipment capable of boiling water for at least five minutes before the water is used, or sterilization equipment or bacteria filtering equipment with the same level of effectiveness as this or greater.

## (2) Cartridge water tank

### **a. Materials**

Components that come into direct contact with water shall be made of materials such as stainless steel that have no risk of elution of toxic or harmful substances and that are resistant to acid and water and are non-permeable.

### **b. Construction**

Openings, such as the water supply tap, shall be designed to be closed off with a lid or plug, for example one that screws on, and shall be designed to prevent exposure during transportation.

### (3) Containers

- a. Containers used to sell food products (does not include soft drinks) must be washed and sterilized. However, this restriction does not apply to containers made of previously unused paper, synthetic resin, paper processed with synthetic resin, aluminum foil or a combination of materials (i.e. have two or more of these: paper, synthetic resin, paper processed with synthetic resin, metal; the same applies below in this category) and that have been disinfected or made with a manufacturing process that has the effect of sterilization and have been handled in such a way that there is no risk of contamination before usage.
- b. Containers used to sell soft drinks must be made of previously unused paper, synthetic resin, paper processed with synthetic resin, aluminum foil or a combination of materials and must have been disinfected or made with a manufacturing process that has the effect of sterilization and handled in such a way that there is no risk of contamination before usage.

## **E-5**

Transportation implements or containers and packaging for liquid raw materials of soft drinks that are prepared and sold by the cup from automatic vending machines and from fully automated soft drink beverage preparation equipment

- (1) Metal transportation implements or containers and packaging must be the following: closed off with a screw-on lid or plug; easy to wash; smooth on the interior surface, and either made of a rust-proof material or treated to prevent rust.
- (2) For synthetic resin transportation implements or containers and packaging, the standard is that described in Part III: Implements, Containers and Packaging, Section E: Application-specific Specifications for Implements, Containers, and Packaging, Paragraph 2: Soft drinks containers and packaging, Division 3: Synthetic resin containers and packaging, paper containers and packaging processed with synthetic resin, aluminum foil containers and packaging processed with synthetic resin. (This standard does not apply to soft drinks that use juice as a raw material, nor does it apply to the categories below.)

## **F. Implements, Containers, and Packaging Production Standards**

### **F-1**

Copper and copper alloy implements, containers, and packaging must be treated so that parts that come in contact with food products are completely covered with tin plating or silver plating or otherwise treated to prevent the risk of sanitary hazards. However, this restriction

does not apply to items with a characteristic gloss and not subject to rust.

## **F-2**

During the production of implements, containers, and packaging, in cases where colorants that are chemically synthesized compounds are used, colorants must not be used unless they are listed in Attached Table 1 of the enforcement regulations of the Food Sanitation Act. However, this restriction does not apply to techniques where the colorant is blended with glaze, glass or enamel, or where other techniques have been used where there is no risk of mixing with food products.

## **F-3**

Frozen confection containers and packaging made of paper, paper-thin sheets of wood, or metal foil must be sterilized after production.

## **F-4**

When manufacturing implements, containers, and packaging, specified cattle backbone must not be used as raw material. However, this restriction does not apply to cases where oils and fats derived from specified cattle backbone are used as raw material after having undergone hydrolysis, saponification or transesterification under high temperature and high pressure conditions.

## III. Standards and Testing Methods for Toys

Ministry of Health, Labour and Welfare

<Toys >

<http://www.mhlw.go.jp/topics/bukyoku/iyaku/kigu/dl/14.pdf>

<http://www.mhlw.go.jp/topics/bukyoku/iyaku/kigu/dl/11.pdf> (in English)

### A. Standards for Toys and Component Materials

#### A-1

Decals must pass the test described below. Distilled water is to be used wherever the test calls for water.

##### (1) Preparation of sample solution

Take a colored piece of the decal and soak it in water heated to 40°C, using 2 ml of water for each 1 cm<sup>2</sup> of surface area. Cover with a watch glass and let sit for 30 minutes, stirring occasionally and maintaining at a temperature of 40°C.

##### (2) Testing

###### a. Heavy metals

When performing testing on 20 ml of sample solution according to Part III: Implements, Containers and Packaging, Section B: Testing Methods for General Implements, Containers and Packaging, Paragraph 4: Heavy metals Test, the results must conform to the standards thereof. To conform, the amount of heavy metals in the form of lead in the sample solution must be no more than 1 µg/ml.

###### b. Arsenic

When performing testing on 20 ml of sample solution according to Part III: Implements, Containers and Packaging, Section B: Testing Methods for General Implements, Containers and Packaging, Paragraph 7: Arsenic Test, the results must conform to the standards thereof. To conform, the amount of arsenic in the form of arsenic trioxide in the sample solution must be no more than 0.1 µg/ml.

#### A-2

Origami paper must pass the test described below. Distilled water is to be used wherever the test calls for water.

##### (1) Preparation of sample solution

Soak a sample in water heated to 40°C, using 2 ml of water for each 1 cm<sup>2</sup> of surface area.

Cover with a watch glass and let sit for 30 minutes, stirring occasionally and maintaining at a temperature of 40°C.

## (2) Testing

### a. Heavy metals

The method used is that described in Part IV: Toys, Section A: Standards for Toys and Component Materials, Paragraph 1-(2): Testing, Sub-paragraph a.: Heavy metals.

### b. Arsenic

The method used is that described in Part IV: Toys, Section A: Standards for Toys and Component Materials, Paragraph 1-(2): Testing, Sub-paragraph b.: Arsenic.

## **A-3**

Rubber pacifiers must pass the test described in Part III: Implements, Containers, and Packaging, Section D: Separate Standards for Implements, Containers, Packaging, and Component Materials, Paragraph 3: Rubber Implements, Containers, or Packaging, Sub-paragraph 2: Testing Methods for Rubber Pacifiers and Artificial Nipples.

## **A-4**

Coating film of toys must pass the test described below.

### (1) Preparation of sample solution

Prepare test specimens by scraping the coating film from toys and pulverizing it finely enough to pass through a 0.5-mm mesh. For coating film made from synthetic resin or other materials that have un-crushable elasticity, the test specimen shall be coating film that is scraped as finely as possible. Accurately measure at least 100 mg of test specimen, add 50 times volume of 0.07 mol/l hydrochloric acid, and shake for 1 hour at 37°C in the dark. Let this preparation stand for 1 hour at 37°C, and then filter it. In the case that the test specimen is at least 10 mg but less than 100 mg, perform the test after adding 5 ml of 0.07 mol/l hydrochloric acid. In the case that the test specimen is less than 10 mg, the test should not be performed.

0.07 mol/l hydrochloric acid: Dissolve 6.3 ml of HCl [K 8180, Special] in distilled water to bring the total volume to 1,000 ml.

### (2) Testing

#### 1) Cadmium, lead and arsenic

Measure 0.1 ml of cadmium control solution, 0.1 ml of lead control solution and 1.3 ml of arsenic control solution. Add to this 0.07 mol/l hydrochloric acid to bring the total volume to

100 ml.

0.1 ml of this solution will contain 1 µg each of cadmium, lead and arsenic. Dilute this solution with 0.07 mol/l hydrochloric acid, and determine analytical curves of cadmium, lead and arsenic by the same method used for determining the analytical curve of the sample solution. Cadmium control solution, lead control solution and arsenic control solution are those described in Part III: Implements, Containers and Packaging, Section C: Reagents and Solutions, Paragraph 4: Control solutions, control undiluted solutions.

For sample solution, determine the cadmium, lead and arsenic contents by the testing methods described in Part III: Implements, Containers and Packaging, Section B: Testing Method for General Implements, Containers and Packaging, Paragraph 3: Atomic Absorption Spectrometry or Paragraph 9: Inductively Coupled Plasma Photoemission Spectroscopy. The elution volume per 1 g of test specimen calculated using the equation below must be no more than 75 µg/g for cadmium, no more than 90 µg/g for lead and no more than 25 µg/g for arsenic. In measuring arsenic by atomic absorption spectrometry, the wavelength of 193.7 nm is used.

Elution volume (µg/g) = ((Sample solution concentration (µg/ml) × sample solution volume (ml)) / (test specimen amount (g) × (100 – the correction value)) / 100

In this equation, the correction value for cadmium and lead is 30, and that for arsenic is 60.

## **A-5**

Coating film coated by using polyvinyl chloride must pass the test described below, as well as the test described in Part IV: Toys, Section A: Standards for Toys and Component Materials, Paragraph 4: Testing Methods. Distilled water is to be used wherever the test calls for water.

### (1) Preparation of sample solution

The test specimen must be a coated toy or a piece sampled from a coated toy. Immerse the test specimen in 2 ml of 40°C water for each 1 cm<sup>2</sup> of surface area of the test specimen, cover it with watch glass and let it stand for 30 minutes at 40°C, stirring occasionally.

### (2) Testing

#### **a. Potassium permanganate consumption**

When adding water to 50 ml of sample solution to make 100 ml and performing testing on this according to Part III: Implements, Containers and Packaging, Section B: Testing Methods for General Implements, Containers and Packaging, Paragraph 1: Testing Method for Potassium Permanganate Consumption, the amount of potassium permanganate consumption found with the following formula must be no more than 50 µg/ml.

$$\text{Potassium permanganate consumption (µg/ml)} = ((a-b) \times 0.316 \times f \times 1,000) / 50$$

Where, a: Titration volume (ml) of 0.002 mol/l potassium permanganate solution in this test

b: Titration volume (ml) of 0.002 mol/l potassium permanganate solution in blank test  
f: 0.002 mol/l potassium permanganate solution factor

**b. Evaporation residue**

When taking 200 – 300 ml of sample solution and performing testing on this according to Part III: Implements, Containers and Packaging, Section B: Testing Methods for General Implements, Containers and Packaging, Paragraph 5: Testing Method for Evaporation residue, the amount of evaporation residue must be no more than 50 µg/ml.

**A-6**

Parts (excluding coating film) manufactured using materials mainly of polyvinyl chloride must pass the test described below. Distilled water is to be used wherever the test calls for water.

(1) Preparation of sample solution

Use toys or a piece of the toys as the test specimen. Immerse the test specimen in 2 ml of 40°C water for each 1 cm<sup>2</sup> of surface area of the test specimen, cover it with watch glass and let it stand for 30 minutes at 40°C, stirring occasionally.

(2) Testing

**a. Potassium permanganate consumption**

The method is that described in Part IV: Toys, Section A: Standards for Toys and Component Materials, Paragraph 5-(2): Testing, Sub-paragraph a.: Potassium Permanganate Consumption.

**b. Heavy metals**

The method used is that described in Part IV: Toys, Section A: Standards for Toys and Component Materials, Paragraph 1-(2): Testing, Sub-paragraph a.: Heavy metals.

**c. Cadmium**

When adding five drops of nitric acid to 100 ml of sample solution and performing cadmium testing according to Part III: Implements, Containers and Packaging, Section B: Testing Method for General Implements, Containers and Packaging, Paragraph 3: Atomic Absorption Spectrometry or Paragraph 9: Inductively Coupled Plasma Photoemission Spectroscopy, the results must conform to the standards thereof. However, for the cadmium control solution, take 10 ml of the cadmium control solution in Part III: Implements, Containers and Packaging, Section C: Reagents and Solutions, add water to make 100 ml, add five drops of nitric acid and use this. To conform, the amount of cadmium in the sample solution must be no more than 0.5 µg/ml.

**d. Evaporation residue**

The method used is that described in Part IV: Toys, Section A: Standards for Toys and Component Materials, Paragraph 5-(2): Testing, Sub-paragraph b.: Evaporation residue.

**e. Arsenic**

The method used is that described in Part IV: Toys, Section A: Standards for Toys and Component Materials, Sub-paragraph 1-(2): Testing, Sub-paragraph b.: Arsenic.

**A-7**

Toys must not be made with any synthetic resin whose primary component is polyvinyl chloride made with bis (2-ethylhexyl) phthalate.

**A-8**

Toys falling under Article 78-1 of the Enforcement Regulations of the Food Sanitation Act must not be made with any synthetic resin whose primary component is polyvinyl chloride made with diisononyl phthalate.

**A-9**

Parts (excluding coating film) manufactured using materials mainly of polyethylene must pass the test described below. Distilled water is to be used wherever the test calls for water.

(1) Preparation of sample solution

Use toys or a piece of the toys as the test specimen. Immerse the sample in 2 ml of 40°C water for each 1 cm<sup>2</sup> of surface area. Cover with a watch glass and let sit for 30 minutes, stirring occasionally and maintaining at a temperature of 40°C.

For a granular sample, wash the sample thoroughly with water, then dry. Next, submerge the sample in 2 ml of 40°C water for each 0.1 g of sample, then cover with a watch glass and let sit for 30 minutes, stirring occasionally and maintaining at a temperature of 40°C.

(2) Testing

**a. Potassium permanganate consumption:**

When a sample is tested according to the method described in Part IV: Toys, Section A: Standards for Toys and Component Materials, Paragraph 5-(2): Testing, Sub-paragraph a.: Potassium Permanganate Consumption, the concentration must not be greater than 10µg/ml.

**b. Heavy metals:**

The method used is that described in Part IV: Toys, Section A: Standards for Toys and Component Materials, Paragraph 1-(2): Testing, Sub-paragraph a.: Heavy metals.

**c. Evaporation residue:**

When a sample is tested according to the method described in Part IV: Toys, Section A: Standards for Toys and Component Materials, Paragraph 4-(2): Testing, Sub-paragraph d.: Evaporation residue, the concentration must not be greater than 30µg/ml.

**d. Arsenic**

The method used is that described in Part IV: Toys, Section A: Standards for Toys and Component Materials, Paragraph 1-(2): Testing, Sub-paragraph b.: Arsenic.

**A-10**

Metallic accessories and toys that might be swallowed by infants and small children must pass the test described below. Metallic accessories and toys that might be swallowed by infants and small children are those that can be placed without compression into the containers described in the following figure.

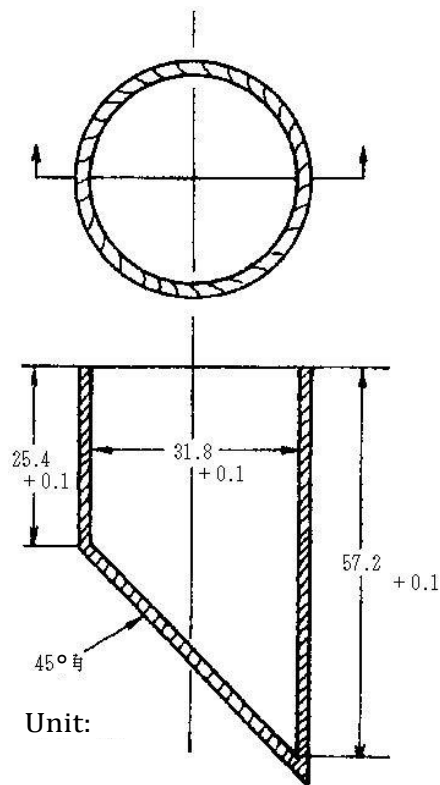

**(1) Preparation of sample solution**

Place the test specimen in a beaker with a 40-mm diameter. Add 0.07 mol/l hydrochloric acid until the test specimen is fully immersed, and let it stand for 1 hour at 37°C in the dark; then, filter it.

0.07 mol/l hydrochloric acid: Dissolve 6.3 ml of HCl [K 8180, Special] in distilled water to bring the total volume to 1,000 ml.

## (2) Lead

Measure 0.1 ml of lead control solution and add 0.07 mol/l hydrochloric acid to bring the total volume to 100 ml. 0.1 ml of this solution will contain 1 µg of lead. Dilute this solution with 0.07 mol/l hydrochloric acid and determine analytical curves of lead by the same measuring method as that for the sample solution. The lead control solution is that described in Part III: Implements, Containers and Packaging, Section C: Reagents and Solutions, Paragraph 4: Control solutions, control undiluted solutions.

For the sample solution, determine the lead content by the testing method described in Part III: Implements, Containers and Packaging, Section B: Testing Method for General Implements, Containers and Packaging, Paragraph 3: Atomic Absorption Spectrometry or Paragraph 9: Inductively Coupled Plasma Photoemission Spectroscopy. The lead eluted from 1 g of test specimen, calculated using the following equation, must not exceed 90 µg.

Elution volume (µg/g) = ((Sample solution concentration (µg/ml) × sample solution volume (ml)) / (test specimen amount (g) × (100 – the correction value)) / 100

In this equation, the correction value for lead is 30.

## A-11

In place of specified methods prescribed in A1 – A10, an alternative method may be used if said method provides equal or greater precision than the specified method. However, if the results obtained are suspect, the final decision is to be made according to the specified method.

## B. Toys Production Standards

When using synthetic resin-based coloring agents in the manufacture of toys, no coloring agent other than those listed in Attached Table 1 of the Implementation Regulations of the Food Sanitation Act shall be used. However, this restriction does not apply to coloring agents that pass the following test.

Place a colored piece of the sample in water heated to 40°C, using 2 ml of water for each 1 ml of surface area. Cover with a watch glass and let sit for 10 minutes, stirring occasionally and maintaining at a temperature of 40°C. This is the sample solution. Place 50 ml of sample solution in a Nessler bottle measuring 20 mm in its inner diameter, 24 mm in its outer diameter, and 20 cm deep from its inner bottom to the bottom surface of the stopper, and graduated every 5 ml up to 50 ml. When viewed from the top and side against a white background, no precipitation of the coloring agent should be visible.

## IV. Standards and Testing Methods for Detergents

Ministry of Health, Labour and Welfare

<Detergents>

<http://www.mhlw.go.jp/topics/bukyoku/iyaku/kigu/dl/6.pdf> (Japanese only)

### A Standards for Detergent Ingredients (excluding detergents intended for use in dishwashing)

#### A-1

The detergent (excluding solid soap) must be suitable for testing using the following testing method. (For detergents in other than liquid form, exclude (3) methanol.) Use distilled water for testing.

##### (1) Arsenic

For fatty acid-based detergents (here meaning detergents that do not contain surfactants other than high fatty acid salt- and high fatty acid ester-based surfactants), dilute samples 30 times with water. For detergents other than fatty acid-based detergents, dilute samples 150 times with water. Use the diluted samples as test solutions. Put 75 ml of the test solution into an evaporating dish and heat it on a water bath until most of the liquid evaporates. Transfer the residual liquid to a decomposition flask, rinse the evaporating dish with a little water, and add that liquid to the decomposition flask. Add 10 ml of nitric acid to the flask, mix well, and heat gently until an intense reaction is observed. When that reaction is finished, allow the solution to cool. Next, add 5 ml of sulfuric acid and heat until white smoke appears. When the liquid takes on a color, cool and then add 5 ml of nitric acid and heat again. Repeat this procedure until the liquid becomes clear or turns a light yellow color. After cooling, add water until the total volume is 50 ml.

Take 20 ml of this liquid, add 10 ml of saturated ammonium oxalate solution and heat until white smoke appears again. After cooling, add water and use this as the sample solution. Test the solution according to Part III: Implements, Containers and Packaging, Section B: Testing Method for General Implements, Containers and Packaging, Paragraph 7: Arsenic Test. It should not turn a darker color than the standard color during this test.

#### Reagents

- Nitric acid: Use nitric acid (special grade).
- Sulfuric acid: Use sulfuric acid (special grade).
- Ammonium oxalate: Use ammonium oxalate (special grade).

##### (2) Heavy metals

Place 100 ml of the sample solution prepared in paragraph (1) in an evaporation dish and heat it on a water bath until most of the liquid evaporates. Transfer the residual liquid to a decomposition flask, rinse the evaporation dish with a little water, and add that liquid to the decomposition flask. Add 10 ml of nitric acid, mix well and heat gently until an intense reaction is observed. When the reaction is finished, allow the solution to cool. Next, add 5 ml of sulfuric acid and heat until white smoke appears. When the liquid takes on a color, cool and then add 5 ml of nitric acid and heat again. Repeat this procedure until the liquid becomes colorless or turns a light yellow color. After cooling, add water until the total volume is 100 ml. Place 20 ml of this liquid in a quartz evaporation plate and heat it on a water bath until most of the liquid evaporates, then carefully heat the residue over a direct flame until it dries and hardens. If necessary, add 1 ml of sulfuric acid and continue to heat until most of the residue turns to white ash. To this add 2 ml of hydrochloric acid and 0.5 ml of nitric acid, then heat it on a water bath until the solution evaporates, leaving a dry, hard residue. Add 1 ml of hydrochloric acid (23→100) and 15 ml of water and heat to dissolve the residue into the solution. After cooling, add 1 drop of a phenolphthalein–ethanol solution (1→100), then add drops of ammonium hydroxide (1→3) until the sample turns a faint red color. Next, add 2 ml of acetic acid (3→50) and, if necessary, filter. Place the filtrate in a Nessler tube and add water until the total volume is 50 ml. Place 2 ml of lead standard solution in a separate Nessler tube and add 2 ml of acetic acid (3→50) and enough water to bring the total volume to 50 ml. This is the control solution. To both solutions add 2 drops of sodium sulfide. Mix well and let sit for 5 minutes, then view both Nessler tubes from the top and sides against a white background. The sample solution should not appear darker in color than the control solution.

### Reagents

- Nitric acid: Use nitric acid (special grade).
- Sulfuric acid: Use sulfuric acid (special grade).
- Hydrochloric acid: Use hydrochloric acid (special grade).
- Ammonium hydroxide: Use ammonium hydroxide (special grade).
- Phenolphthalein–ethanol solution: Use 1 g of phenolphthalein (special grade) in solution with 100 ml of ethanol (95% by volume, special grade).
- Acetic acid: Use acetic acid (special grade).
- Lead standard solution: Use a lead standard solution that complies with Part II: Additives, Section C: Reagents and Solutions, Paragraph 3: Standard Solutions.
- Sodium sulfide solution: Use a sodium sulfide solution that complies with Part II: Additives, Section C: Reagents and Solutions, Paragraph 1: Reagents and Solutions.

### (3) Methanol

Add 10 g of isopropyl alcohol (as an internal standard substance) to 100 g of sample and mix well; issue this as the test solution. Create a control solution by mixing 10 g of isopropyl alcohol with 100 ml of methanol (1→1,000) with water.

When subjecting 1 µl of test solution and 1 µl of control solution to gas chromatography under the operating conditions specified below, the ratio  $A/AS$ , where  $A$  is the peak surface area of methanol in the test solution and  $AS$  is the peak surface area of the internal standard substance, must not exceed the ratio  $A'/A'S$ , where  $A'$  is the peak surface area of methanol in the control solution and  $A'S$  is the peak surface area of the internal standard substance. For both the test solution and the control solution, change the sensitivity so that the sensitivity of the part near the peak of methanol is approximately 32 times that of the part near the peak of the internal standard substance. Use the half-power bandwidth method to determine peak surface area.

#### **Operating conditions**

- Detector: Flame ionization detector
- Column packing material: 170 to 300 µm porous polymer beads for gas chromatography
- Column tubes: Use glass or stainless steel tubes 2 to 3 m long and with an inner diameter of 3 to 4 mm.
- Column tube temperature: Constant temperature between 130 and 150°C
- Test solution inlet temperature: Constant temperature 30 to 50°C higher than the column tube temperature
- Carrier gas: Use high-purity nitrogen. Adjust to a velocity such that the isopropyl alcohol flows out in 8 to 10 minutes.

#### **Reagent**

- Isopropyl alcohol: Use isopropyl alcohol (special grade).
- Methanol: Use methanol (special grade).

#### **(4) Liquidity**

When measured with a glass electrode pH meter, the pH of the test liquid obtained by the same means as (1) using boiled and cooled water must be between 6.0 and 10.5 in the case of fatty acid-based detergents and between 6.0 and 8.0 in the case of all other detergents.

#### **A-2**

A detergent must not contain enzymes or any component with a bleaching effect.

#### **A-3**

A detergent must not contain any artificial aromatic agent other than those listed in Attached Table 1 of the Implementation Regulations of the Food Sanitation Act.

#### **A-4**

A detergent must not contain any artificial coloring agent other than those listed in Attached

Table 1 of the Implementation Regulations of the Food Sanitation Act.

- Indanthrene RS (N,N'-dihydro-1,2,1',2'- anthraquinone-azine)
- Wool Green BS (4,4-bis (dimethylamino) diphenylmethylen-2-naphthol-3,6-disulphonic acid monosodium salt)
- Quinoline yellow (2-(2 quinolyl)-1,3-indandione-disulphonic acid disodium salt)
- Patent blue V (m-hydroxy-tetraethyl-diaminotriphenylcarbinol-disulphonic acid calcium salt)

## **A-5**

A detergent containing an anionic surfactant must have a biodegradability of at least 85%.

## **B. Standards for Using Detergents**

### **B-1**

The surfactant concentration must not exceed 0.5% in the case of fatty acid-based detergents or 0.1% in the case of all other detergents (excluding solid soap and detergents intended for use in dishwashing).

### **B-2**

When using a detergent (excluding detergents intended for use in dishwashing; the same applies to the following items), vegetables and fruits must not be soaked in the detergent solution for more than 5 minutes.

### **B-3**

Fruits, vegetables, or eating or drinking utensils must be rinsed with potable water after being washed with a detergent. When rinsing in flowing water, rinse fruits or vegetables for at least 30 seconds and eating or drinking utensils for at least 5 seconds. When using collected water, change the water and rinse in clean water at least twice.